

# HANDY-HERMAN

Models: 16DC, 16AC  
24DC, 24AC

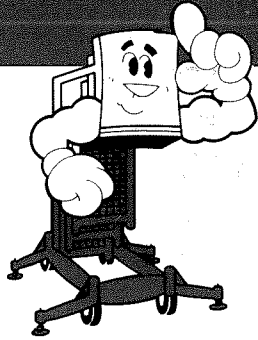

## Operating, Service and Maintenance Manual

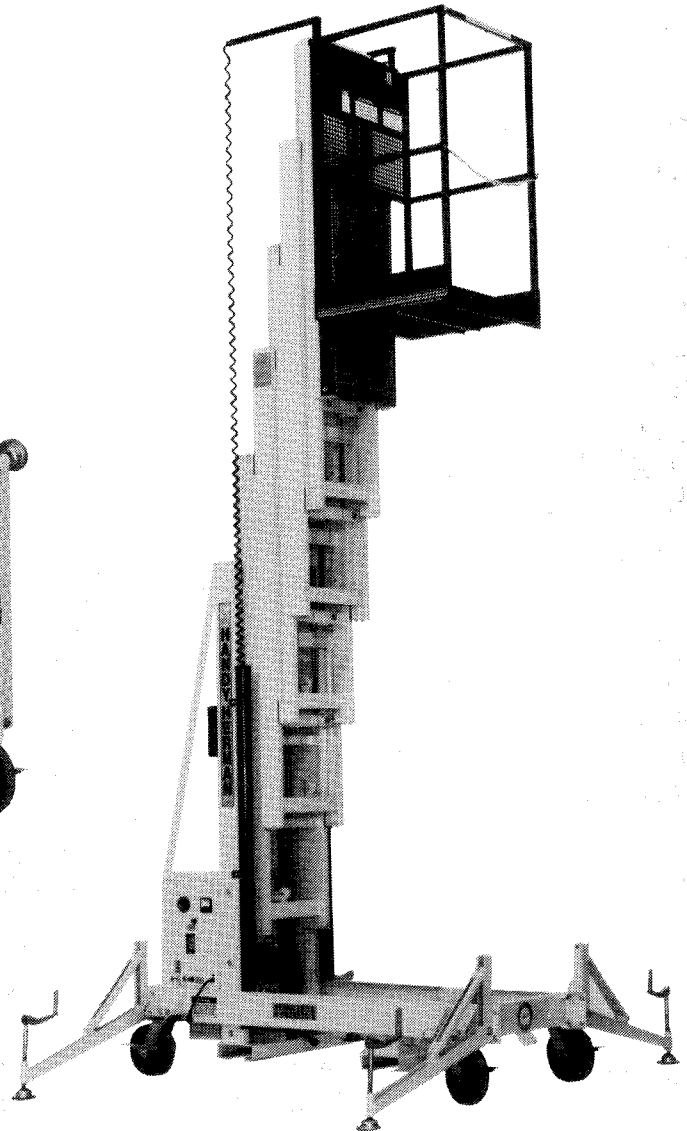

PAC-CRAFT PRODUCTS  
A DIVISION OF  
MAYVILLE ENGINEERING COMPANY, INC.  
715 SOUTH STREET, P.O. BOX 267  
MAYVILLE, WISCONSIN 53050

6548  
REV. 1  
1/88

## TABLE OF CONTENTS

1. INTRODUCTION .....	1
Operator Qualifications .....	1
Safety and Limitations .....	1
Description .....	1
Specifications .....	2
2. OPERATION .....	2
Safety Features .....	2
Operating Instructions .....	5
3. MAINTENANCE .....	6
Use of NOTES, CAUTIONS and WARNINGS .....	6
Inspection and Lubrication .....	7
Servicing, Replacement and Adjustments .....	11
4. TROUBLESHOOTING .....	17
5. PARTS CATALOG .....	23

## LIMITED OWNER WARRANTY

Pac Craft Products warrants its equipment, to the original purchaser only, against defects in workmanship and materials under normal use and service for one (1) year from date of authenticated purchase or date equipment is first placed in use, whichever is earlier; excluded from such warranty is the battery which carries a ninety (90) day warranty from such date of purchase and prorated thereafter up to one (1) year from such date of purchase. Warranty within such warranty period is limited to replacement or repair, at Pac Craft's option, of equipment or parts thereof shipped prepaid to Pac Craft which are found, upon inspection by Pac Craft, to be defective. Pac Craft's sole obligation and buyer's exclusive remedy hereunder shall be limited to such repair or replacement.

PAC CRAFT SHALL NOT BE LIABLE FOR ANY CONSEQUENTIAL, INCIDENTAL OR CONTINGENT DAMAGES WHATSOEVER. USE OF OTHER THAN FACTORY AUTHORIZED PARTS, MISUSE, IMPROPER MAINTENANCE OR MODIFICATION OF THE EQUIPMENT VOIDS THIS WARRANTY. PARTS OTHER THAN OF OUR MANUFACTURE ARE SUBJECT TO THE ORIGINAL MANUFACTURER'S WARRANTY.

THE FOREGOING WARRANTY IS EXCLUSIVE AND IN LIEU OF ALL OTHER WARRANTIES, EXPRESS OR IMPLIED. ALL SUCH OTHER WARRANTIES, INCLUDING THE IMPLIED WARRANTIES OF MERCHANTABILITY AND OF FITNESS FOR A PARTICULAR PURPOSE, ARE HEREBY EXCLUDED.

NO DEALER, SALES REPRESENTATIVE OR OTHER PERSON PURPORTING TO ACT ON BEHALF OF PAC CRAFT IS AUTHORIZED TO ALTER THE TERMS OF THIS WARRANTY OR TO IN ANY MANNER ASSUME ON BEHALF OF PAC CRAFT ANY LIABILITY OR OBLIGATION WHICH EXCEEDS PAC CRAFT'S OBLIGATIONS UNDER THIS WARRANTY.

# 1. INTRODUCTION

## OPERATOR QUALIFICATIONS

Handy-Herman is to be operated and maintained by qualified personnel only!

To qualify for operation and maintenance of this unit, an individual must read and thoroughly understand this manual. If a proposed operator or maintenance man fails to understand any segment of this manual, his Supervisor can clarify the misunderstanding through written correspondence or a phone call to:

Pac Craft Products  
Division of Mayville Engineering Company, Inc.  
715 South Street, P.O. Box 267  
Mayville, Wisconsin 53050  
#414-387-4500

## SAFETY AND LIMITATIONS

Pac-Craft designs Handy-Herman aerial work platforms to be safe and reliable. They are rugged and maneuverable but must be used only for purposes and ways intended.

The following precautions are based on common sense and on the code of safe practices developed by the Scaffold Industry Association, Inc. for the elevating work platform industry.

1. Respect your machine: do not neglect or misuse it.
2. Check jobsite for unsafe working conditions.
3. Inspect machine before using. Do not use machine if it is malfunctioning in any way.
4. Use machine only for purposes for which it was designed.
5. Never take chances. Do not use machine if your physical condition is uncertain in any way.
6. The platform and its enclosures are not insulated. Do not use near electrically energized circuits.
7. An operator of any type of work platform is subject to certain hazards that cannot be protected by mechanical means. It is therefore essential that operators be competent, careful, physically and mentally fit, and thoroughly trained in safe operation of this machine.

## DESCRIPTION

### General

Handy-Herman aerial work platforms are electrically actuated, hydraulically operated units. The platform is raised and lowered by mast sections. Emergency lowering and auxiliary lift controls are located at the base of the machine.

# HANDY-HERMAN SPECIFICATIONS

MODEL NO.	(EXT.) PLAT. HT.	(EXT.) WORK HT.	LIFT CAP	POWER	BASE LENGTH	BASE WIDTH	BASE WIDTH w/ OUTRIG. EXT.	PLAT. WIDTH	PLAT. LENGTH	GRND. CLEAR	APPROX. WT.†	ASCEND TIME (LOADED)	DESCEND TIME (LOADED)
16AC	16' (4.88m)	22' (6.71m)	400# (181.6kg)	AC 115V	5'3" (1.60m)	2'6" (.76m)	5'2" (1.20m)	24" (.61m)	30" (.76m)	3" (76mm)	763# (346.3kg)	35 sec.	25 sec.
16DC	16' (4.88m)	22' (6.71m)	400# (181.6kg)	DC 12V	5'3" (1.60m)	2'6" (.76m)	5'2" (1.20m)	24" (.61m)	30" (.76m)	3" (76mm)	824# (374.0kg)	35 sec.	25 sec.
24AC	24' (7.32m)	30' (9.14m)	300# (136.2kg)	AC 115V	5'3" (1.60m)	2'6" (.76m)	5'2" (1.20m)	24" (.61m)	24" (.61m)	3" (76mm)	885# (401.7kg)	35 sec.	25 sec.
24DC	24' (7.32m)	30' (9.14m)	300# (136.2kg)	DC 12V	5'3" (1.60m)	2'6" (.76m)	5'2" (1.20m)	24" (.61m)	24" (.61m)	3" (76mm)	946# (429.3kg)	35 sec.	25 sec.

† Add approximately 100# (45.4kg) for skid weight.

## 2. OPERATION

### SAFETY FEATURES

#### 1. Emergency Stop

The emergency stop is located on the control console. Depress red knob as indicated and all functions of machine will be de-energized. Pull up on knob to reactivate circuits. (Fig. 1)

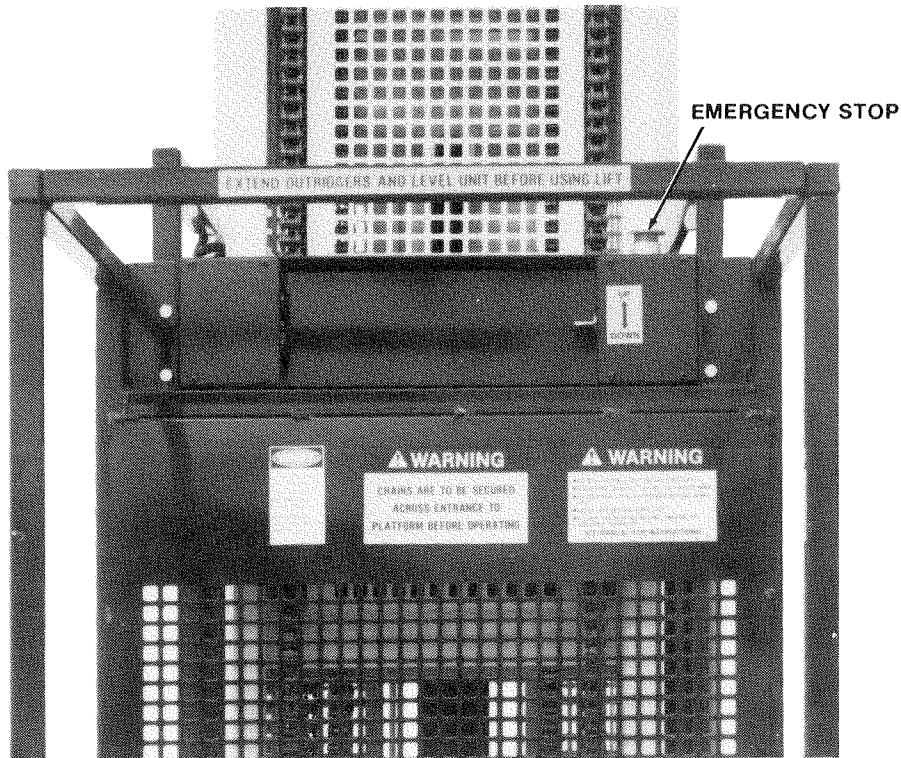

Figure 1. Emergency Stop Control

2. **Emergency Down**

The Emergency Down Control is located below the hydraulic reservoir in the rear of the unit. Pull handle on cable to allow platform to descend back to the stowed position. (Fig. 2)

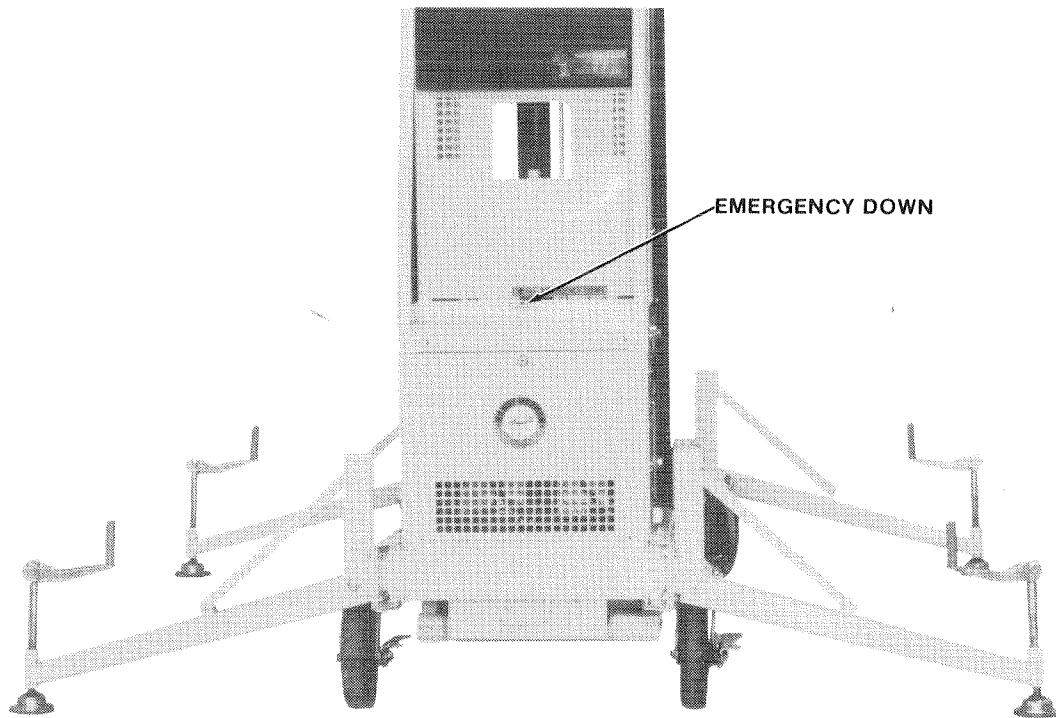

Figure 2. Emergency Down Control

3. **Caster Brakes**

Caster brakes must be set whenever platform is elevated. (Fig. 3)

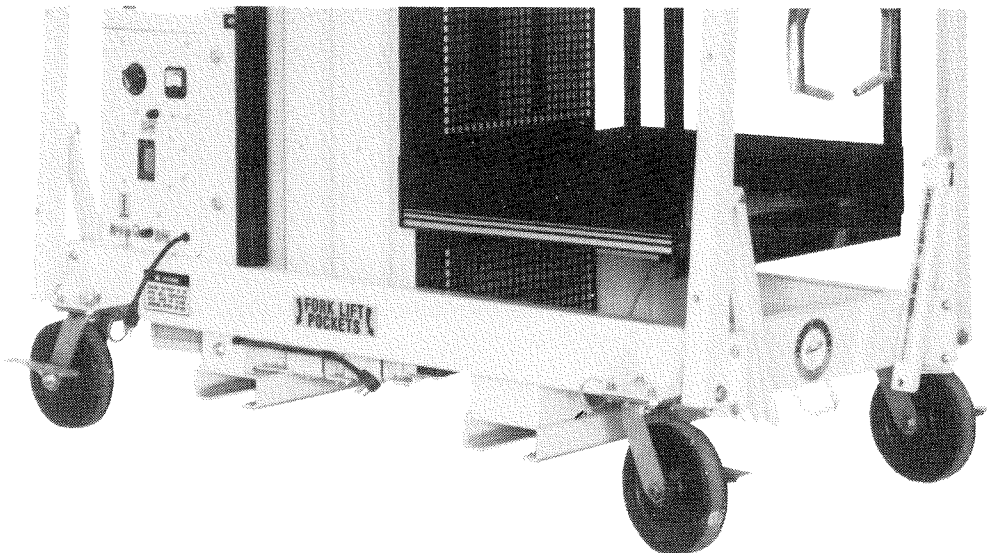

Figure 3. Caster Brakes

4. **Manual Outriggers**

Outriggers must be extended whenever platform is elevated. When positioning unit for work, leave approximately 25 inches of space for outrigger extension between the unit and any obstruction on both sides of the machine. (Fig. 4)

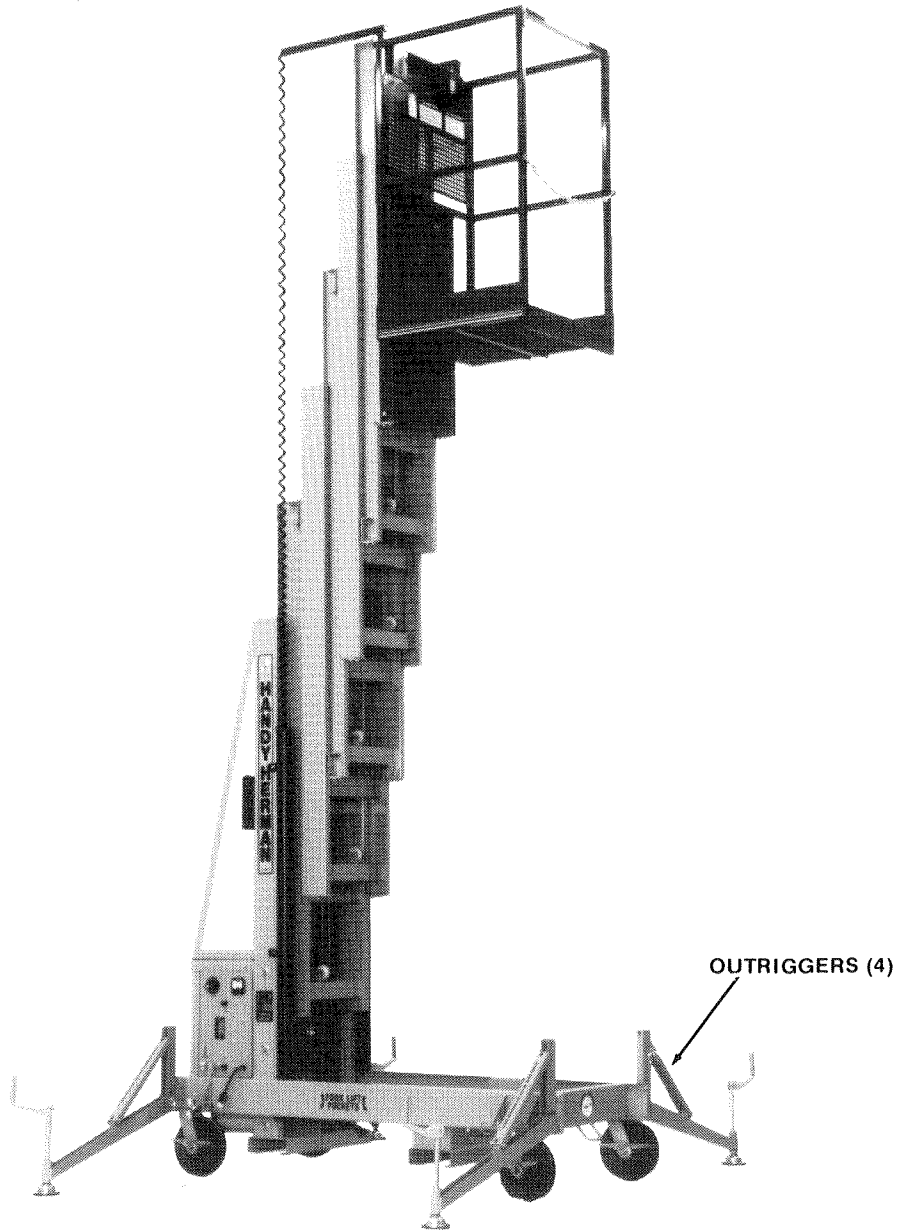

Figure 4. Manual Outriggers



# OPERATING INSTRUCTIONS

## A. ALL MODELS

1. Always extend and adjust all outriggers so base is level before extending.

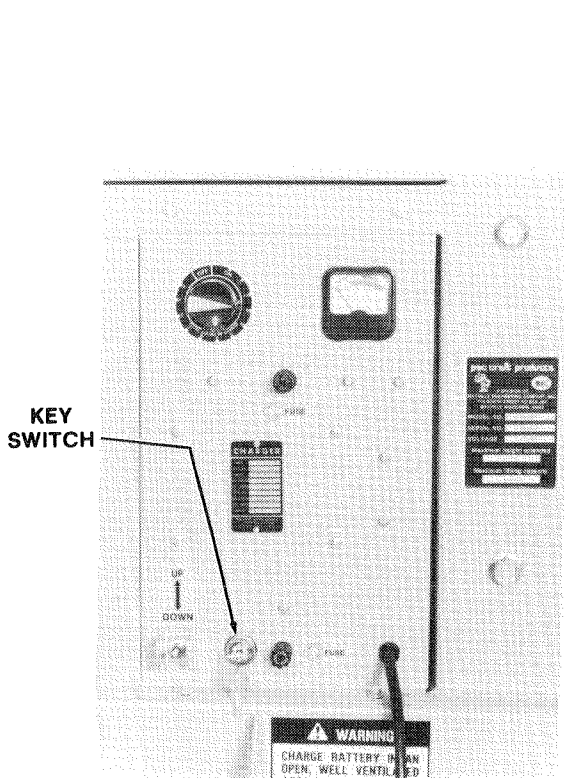

Figure 5. Key Switch Location

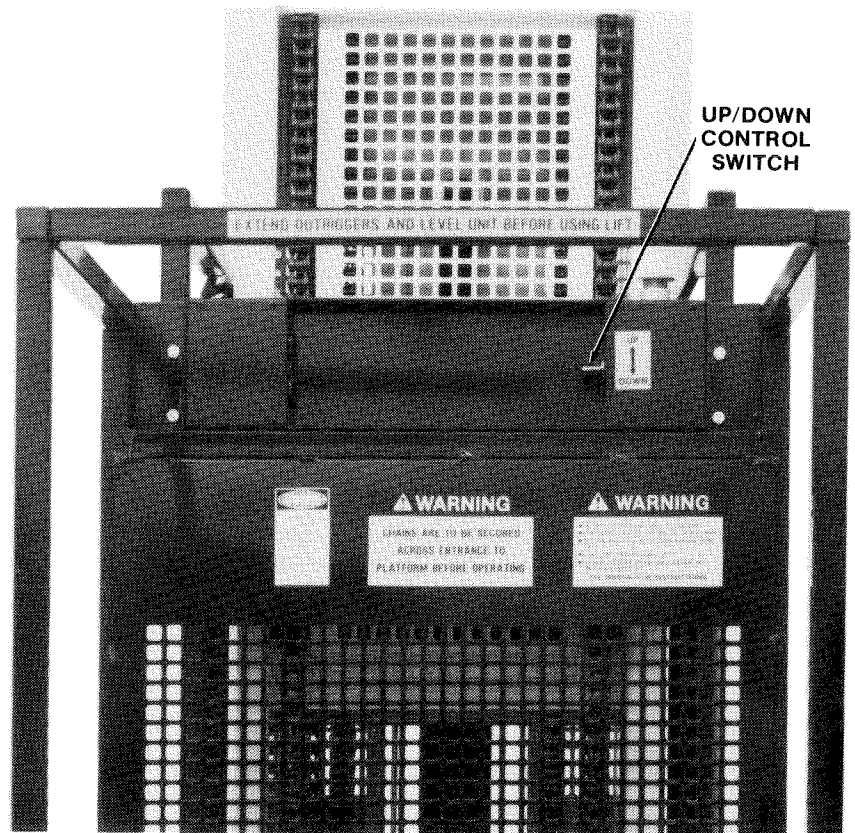

Figure 6. Control Switch Location

2. To operate the Handy-Herman you must first turn the key to the ON position. The key is located at the lower control and charger panel. (Fig. 5) You must also have battery switch in ON position for D.C. units. This is located in the opposite side panel.
3. **To Raise Platform** — Activate up/down toggle switch to UP position. To stop platform, release switch. (Fig. 6)
4. **To Lower Platform** — Activate up/down toggle switch to DOWN position. To stop platform, release switch. (Fig. 6)

## GENERAL OPERATING RULES AND SAFETY

1. The following instructions must be complied with to ensure safe operation of the Handy-Herman work platform.
2. Before operation — Ensure that the machine is properly serviced. (**Do Not Use** if machine is not working properly.)
3. Inspect the unit for damaged or defective parts before each use. Any damage or defects shall be repaired before operating.
4. Ensure that safety chain is in place whenever someone is on the platform. Do not operate without platform safety chain in place.
5. Follow all applicable city, state, federal, OSHA and ANSI A92.3 safety codes for use of elevating work platforms.
6. **Do Not** use near power lines . . . Platform and enclosure are **not** insulated. Stay clear of electric wire, cables, and other overhead obstructions.
7. Do not attempt to use the unit when exposed to wind, rain, snow or ice.
8. **Do Not** elevate on incline. **Do Not** operate on uneven or soft terrain. Operate only on a firm and level surface.
9. Always check clearance around machine before elevating or lowering platform.
10. Do not exceed the load capacity of platform.
11. Always lock caster brakes before elevating platform.
12. Always extend and adjust all outriggers so base is level before boarding.
13. Maintain and lubricate unit daily.

## 3. MAINTENANCE

### USE OF NOTES, CAUTIONS, AND WARNINGS

**NOTE** — Additional information to further understand instructions.

**CAUTION** — Denotes that failure to comply with instructions could cause damage to the equipment.

**WARNING** — Denotes that failure to comply with instructions would create a hazardous condition that could result in injury to personnel.

#### WARNING

Maintenance on the Handy-Herman series is relatively simple with a minimum of servicing required; however, with any type of lifting device, a hazard to personnel exists when maintenance is performed when platform is raised.

When possible, all maintenance should be performed through the rear of the unit.

The battery on D.C. units should be disconnected whenever working on components. **DO NOT REMOVE ANY HYDRAULIC COMPONENTS WITH PLATFORM RAISED.**



## INSPECTION AND LUBRICATION

### 1. Visual Structural Inspection

- a. Visually check unit completely each day to insure the operators safety. Replace or repair any damaged structural members of the unit. Tighten any loose nuts, bolts, or pins. Be sure all plastic guide pads are in place and not damaged in any way. Check to see that outriggers move freely and adjustment screw turns easily.
- b. Inspect all chains for damage daily. Look for signs of wear, broken rollers, pins or links, kinking, corrosion, heat damage, etc. Replace any chain which is damaged in any way or which shows wear in any way. The chain assemblies must be ordered from your dealer to ensure that the original safety and quality specifications are met. Do not use a unit on which any chain assembly is in need of replacement.
- c. Inspect all mast sections daily to make sure that they are free of dirt or other foreign material which in any way restrict the free movement of the guide pads.

### 2. Lubrication

Minor lubrication will make the operation of the Handy-Herman more efficient and extend its useful life.

- a. Grease caster axles and swivel raceways monthly.
- b. Oil the leveling screws monthly.
- c. The plastic guide pads in the mast are self lubricating and should not require any maintenance. However, precautions should be taken to be sure that the paths along which the blocks move are kept clean and lightly lubricated with a dry type silicone lubricant.
- d. Lubricate roller chain and sprockets with EP 90 oil monthly.

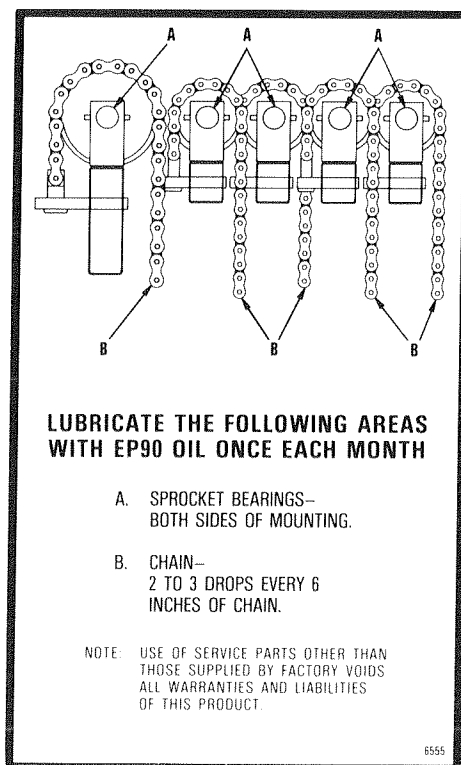

<b>Battery</b>		<p>Keep log as follows:</p> <ol style="list-style-type: none"> <li>1. Inspect components</li> <li>2. Check Boxes if components OK or Make repairs</li> <li>3. Initial boxes</li> </ol> <p>Key: B = Battery H = Hydraulic System M = Mast Section</p>																																				
1. Check Wiring																																						
2. Check Fluid Level																																						
<b>Hydraulic System</b>																																						
1. Check for Leaks																																						
2. Check Hoses																																						
<b>Mast Sections</b>																																						
1. Check for Damaged Chains (Broken Rollers, Pins or Links)																																						
2. Check Sprockets and Guides for Wear.																																						
MONTH																																						
DAY					7																															28		
INIT.																																						
B-1																																						
2																																						
H-1																																						
2																																						
M-1																																						
2																																						
MONTH																																						
DAY						7																															28	
INIT.																																						
B-1																																						
2																																						
H-1																																						
2																																						
M-1																																						
2																																						
MONTH																																						
DAY							7																														28	
INIT.																																						
B-1																																						
2																																						
H-1																																						
2																																						
M-1																																						
2																																						

Table 3A. Inspection and Lubrication Daily Log.

**Check and Initial Every 15 hours of USE, or Weekly**

**COMPONENT**

MONTH  
DAY  
INITIAL

COMPONENT	MONTH												
	DAY												
	INITIAL												
<b>Battery</b>													
1. Clean Battery													
2. Coat Terminals													
<b>Hydraulic System</b>													
1. Check Fluid Level													
2. Inspect Commutator and Brushes*	Date Last Checked _____												
3. Check Fittings													
<b>Mast Sections</b>													
1. Oil Sprockets and Chains													
<b>Main Frame</b>													
1. Grease Caster Axles and Swivel Plates (Manual)													
2. Check Structure and Sprocket Pivot Pins													
<b>Control System</b>													
1. Check Terminals and Plugs													
2. Check Cords													

\* Check every 6 months

**Table 3B. Inspection and Lubrication Weekly Log.**

COMPONENT	TIME INTERVAL				
	DAILY	WEEKLY	MONTHLY	6 MONTHS	1 YEAR
<b>Battery</b> 1. Check Wiring 2. Check Fluid Level 3. Clean Battery Connections 4. Coat Terminals	X X	X X			
<b>Hydraulic System</b> 1. Check for Leaks 2. Check Fluid Level 3. Inspect Commutator and Brushes 4. Check Hoses 5. Check Fittings 6. Oil Filter (Clean)	X X	X X		X	X
<b>Mast System</b> 1. Check for Damage 2. Oil Sprockets and Chains 3. Check for Broken Rollers, Pins or Links (Replace Immediately)	X X		X		
<b>Main Frame</b> 1. Grease Casters 2. Check Structure 3. Check Pivot Pins on Outriggers	X	X			X
<b>Control System</b> 1. Check Terminals and Plugs 2. Check Cords		X X			
<b>Safety Decals*</b> 1. Check if Missing (Add if Necessary) 2. Check if Legible (Replace if Necessary)	X X				

\* See page 24 for safety decals and locations.

**Table 3C. Inspection & Lubrication Schedule.**

## SERVICING, REPLACEMENT AND ADJUSTMENTS

This section contains three basic maintenance functions:  
Servicing, Replacement and Adjustments

**SERVICING** describes items to be checked and serviced when necessary, on a daily basis, or prior to using the unit after it has been out of service for a period of time.

**REPLACEMENT** describes the proper method for removal and installation of replaceable components in case of failure.

**ADJUSTMENT** describes any adjustments necessary to ensure proper operation of the unit or adjustments required after the replacement of components, if necessary.

### CAP SCREWS

**NOTE: Any bolt replacement should be of same grade or greater than original bolt. Any questions, call the factory for verification.**

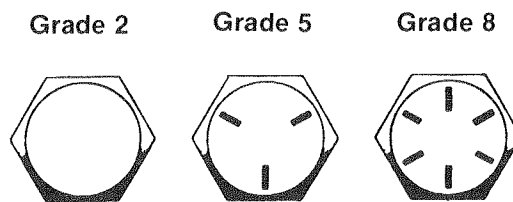

**NOTE: Use only service parts supplied by the factory.**

### 1. BATTERY (DC ONLY)

#### WARNING

NEVER SMOKE OR USE OTHER COMBUSTIBLES NEAR BATTERY WHILE SERVICING BATTERY OR OTHER COMPONENTS. PROVIDE PLENTY OF VENTILATION. PRESENCE OF HYDROGEN FUMES COULD LEAD TO EXPLOSION!

Handy-Herman battery models are supplied with a heavy duty deep-cycle battery. The care and maintenance of your battery has much to do with how well your Handy-Herman functions. Battery wiring and water level should be checked daily. After using Handy-Herman continuously for a period of time, it is recommended that the battery be brought to a full charge as soon as possible. If the battery is allowed to remain discharged, the lead plates will harden and become sulfated. This will shorten their life as much as over-charging. In this sulfated condition the battery fails to deliver its rated capacity or come up to full charge. Several long, slow charges and fast discharges are then necessary to correct the sulfation and hardened plates. It is recommended that once a month the battery be given an equalizing charge of 25% over the regular charge. The equalizing charge must always be given at a low rate to eliminate excessive gassing. Whenever battery temperature reaches 125° F, the charging rate should be reduced or the battery taken off charge and allowed to cool to room temperature.

Do not overfill. When the cells are filled too full, the battery fluid will expand as it becomes warm from charging causing fluid to seep out. Each time this happens, the solution weakens by adding water. Loss of ampere hour capacity will result.

**WARNING**

NEVER SMOKE OR USE OTHER COMBUSTIBLES NEAR BATTERY.  
MAKE SURE THERE IS PLENTY OF VENTILATION. HYDROGEN FUMES  
COULD LEAD TO EXPLOSION.

a. **Checking and Filling** (Every 15 hours of use or when recharging)

- (1) Remove rear guard.
- (2) If there is any dirt or corrosion on battery, wash with solution of 5 teaspoons baking soda per quart of warm water.
- (3) Remove battery caps and check fluid.
- (4) Fill, if needed, as follows:
  - (a) Before charging, fluid must be above plates in battery.
  - (b) After charging, fill to split ring.

**CAUTION**

Do not overfill. Fluid will expand as it becomes warm from charging and seep out of the battery. When water is then added, the solution is weakened and a loss of ampere hour capacity results.

Never add acid to battery. The solution is at its proper strength when the battery is manufactured. Use distilled water and keep fluid up to proper level. When required, water should be added to battery **after** charging, unless water level is below the top of the plates.

- (5) Coat terminals with petroleum jelly or equivalent coating.

b. **Charging Notes**

- (1) The surrounding temperature has a great effect on the power reserve in a battery.
  - (a) A battery 100% charged at 80° F.
    - drops to 65% at 32° F.
    - drops to 40% at 0° F.
  - (b) A battery 46% charged at 80° F.
    - drops to 32% at 31° F.
    - drops to 21% at 0° F.
- (2) When battery temperature reaches 125°, battery should be taken off charge and cooled to room temperature or the charging rate should be lowered.

- (3) Battery should be brought to full charge as soon as possible after continuous use. (Lead plates in discharged batteries become hardened and sulfated. The battery eventually will not deliver its rated capacity or come up to a full charge. Several long slow charges and fast discharges help restore plate condition.)
- (4) Once a month, battery should be given an equalizing charge of 25% over regular charge. Charge must be given at low rate to avoid gassing.

c. **Charging**

- (1) Remove rear guard.
- (2) Remove caps, check fluid level and if needed, fill to cover plates.

**NOTE**

After charging, fill to split ring.

- (3) Plug charger into 120 VAC, 60 HZ power source.
- (4) Turn timer clockwise to "ON" position.
- (5) Charge until meter reads in finish area or near zero (0). (Charge will turn off automatically when timer runs out.)
- (6) Unplug charger.
- (7) Check that fluid level is up to split rings and reinstall caps.

d. **Battery Replacement**

- (1) Completely lower unit.
- (2) Remove rear guard.
- (3) Remove nuts from battery hold down and remove hold down.
- (4) Remove battery cables.
- (5) Remove battery.

## 2. **HYDRAULIC SYSTEM**

a. **General Maintenance**

**CAUTION**

It is important to maintain the hydraulic system continually to keep the oil clean and to prevent possible damage to the system.

- (1) Check the suction and return hoses and fittings (Fig. 7) for leakage or damage each day. Tighten or replace when necessary to prevent loss of hydraulic oil.
- (2) If platform does not stay up, check and clean manual valve, solenoid valves and flow control valve in manifold block. Be sure platform is in stowed (down) position and reservoir is drained when removing any components. Replace valves in original position.

b. **Check and Fill Hydraulic Reservoir**

- (1) Lower platform completely.



- (2) Unscrew the breather cap (Fig. 7) located inside frame member and fill the reservoir with hydraulic fluid conforming to MIL. Spec. 0-5606, Flowmite 150 Hydraulic fluid or a good grade SAE 10W hydraulic oil.

### NOTE

The reservoir should be filled within 2" of top with the platform in its lowest position. Do not overfill because when oil warms it will expand and overflow reservoir.

- (3) Should oil become contaminated, disconnect suction hose and drain reservoir into suitable container. Unscrew suction filter and remove from reservoir. Drain remaining oil from system.
- (4) Clean suction filter in solvent.
- (5) Reassemble components and fill reservoir with clean oil.

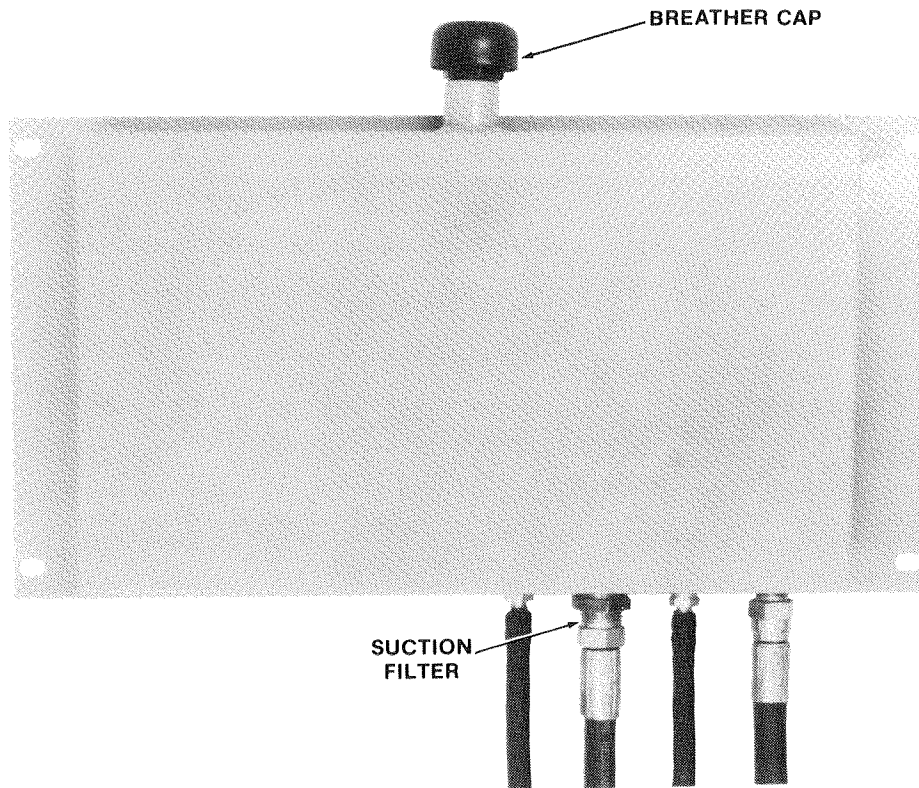

**Figure 7. Filling Hydraulic Reservoir and Checking Hydraulic Oil Filter**

#### c. **Hydraulic System Bleeding**

The Handy-Herman hydraulic system is self-bleeding. After the system has been drained, such as during the replacement of a hydraulic system component, actuate the platform full up and down for two cycles and recheck the reservoir fluid level between each cycle. Fill as required.

**d. Flow Control Valve**

- (1) Raise unit to fully extended position.
- (2) Depress DOWN switch and open or close flow control valve, as necessary, to adjust descent speed of platform to about 9" per second.

**e. Hydraulic Pump Motor Servicing**

- (1) Common maintenance of DC motors is brush replacement. It is recommended that brushes be checked and replaced if necessary along with commutator inspection approximately every six months. The time element will greatly vary depending on how the machine is being used and the condition of the battery. It is to your advantage to keep the battery fully charged and in top condition to eliminate service problems in general and to extend the life of the motor and brushes.
- (2) Common maintenance on AC motors is minor. It should be kept clean and free of obstructions. The motors need no oiling.

**f. Hydraulic Pump and Motor Replacement**

- (1) The hydraulic pump or motor can be replaced together or separately.
- (2) Disconnect positive and negative cables from motor.
- (3) If only motor has to be replaced, unbolt pump from motor leaving hoses connected on pump.
- (4) Remove four bolts securing motor to base and remove motor.
- (5) If only hydraulic pump has to be replaced disconnect hoses from pump.
- (6) Remove four bolts securing pump to the motor and remove pump.
- (7) Motor and pump can be removed by disconnecting cables, hoses, and removing four bolts from base.
- (8) Install new or repaired motor or pump in reverse order of removal.
- (9) Refill reservoir to replace fluid lost during disassembly.
- (10) Raise and lower platform twice to bleed system. Check the fluid level after cycling and fill as required.

**3. BRAKES**

**NOTE**

Brakes are caster mounted on all four casters and are foot operated.

- a. Adjust brake tension of foot pedal to proper tension while having caster raised for free spinning.

#### 4. HYDRAULIC LIFT CYLINDER

##### a. Replacement

- (1) Lower platform completely.
- (2) Remove both battery cables.
- (3) Remove two chains which wrap around first mast section (mast section with cylinder mounted inside).
- (4) Remove pin on top of cylinder rod.
- (5) Wrap chain, sling, or looped cable around top spacer on first mast section.
- (6) Lift first mast section until the cylinder is clear of all center braces. (All the other mast sections will raise with the first.)
- (7) Remove pin from bottom of cylinder, lift out of base mounting bracket and unbolt manifold block from cylinder.
- (8) Replace cylinder and reassemble in opposite order of removal.

#### 5. LIFT ROLLER CHAINS

Adjust the lift chains as follows: Extend all outriggers and level base. Raise the platform to the maximum extended height and then lower it while operator and another person check for chain damage or wear as described above. After completely lowering the platform turn power off on machine and remove mast guards. Adjust the chains until they are just snug against the retainer. Do not overtighten the chains so as to raise the platform from its resting position. Make sure that the hex lock nuts are turned onto the threaded ends with at least one thread extending through the nut. Check both ends that connecting links are secure.

Replace all mast guards.

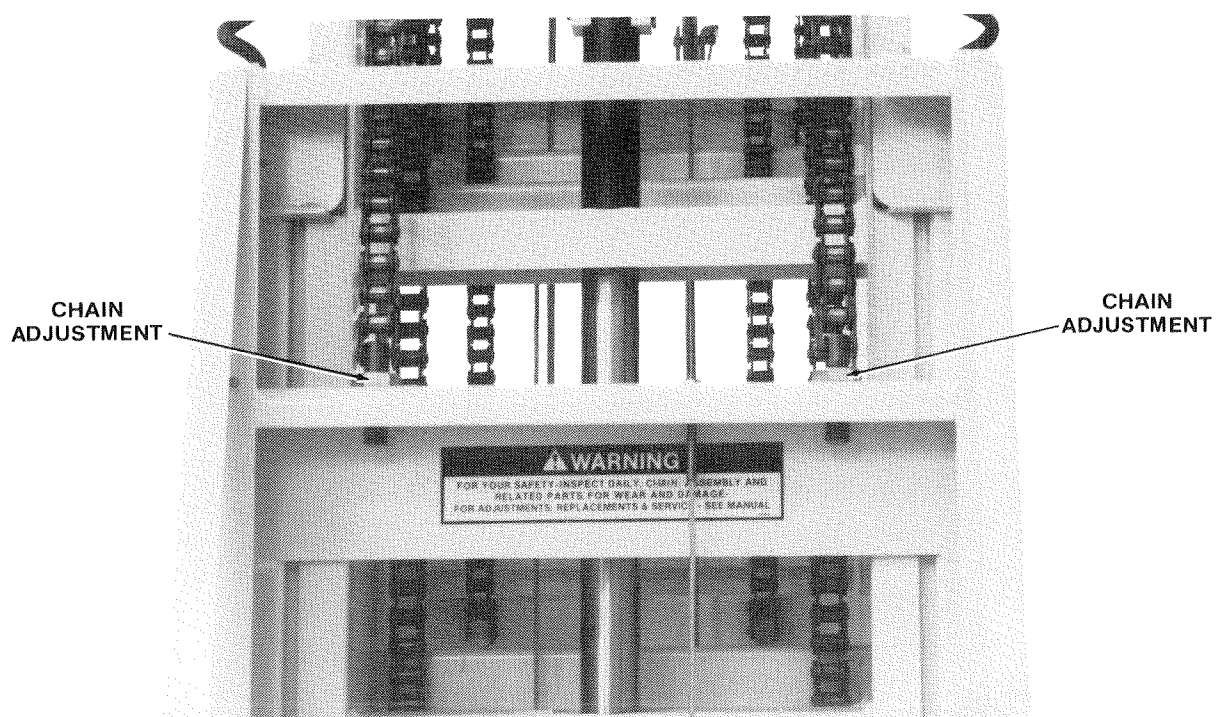

Figure 8. Adjusting Lift Chains

## 4. TROUBLESHOOTING

PROBLEM	POSSIBLE CAUSES	REPAIR PROCEDURE
No LIFT motion pump not operating). (All Models)	1. Blown fuse.	1. Check fuse and replace if necessary.
	2. Dead battery.	1. Check and charge battery as directed in MAINTENANCE section.
	3. Electrical circuit defective.	1. Refer to electrical schematic.
	4. Worn brushes.	1. Replace.
	5. Shorted armature.	1. Replace motor.
	6. Defective motor start solenoid.	1. Replace start solenoid.
	7. Defective emergency stop switch or solenoid.	1. Replace switch or solenoid.
	8. Defective key switch.	1. Replace key switch.
	9. Defective UP switch.	1. Replace UP switch.
	10. Defective battery disconnect.	1. Replace battery disconnect.
No LIFT motion (pump operating) (All Models)	1. Hydraulic fluid level low.	1. Add fluid (see MAINTENANCE section).
	2. Pump cavitation caused by improper fluid for temperature conditions.	1. Drain reservoir and bleed system. Use only recommended type fluids (see MAINTENANCE section).
	3. Defective UP valve or coil.	1. Replace UP valve or coil.
	4. Electrical circuitry defective.	1. Refer to electrical schematic.
	5. Defective emergency down valve.	1. Replace emergency down valve.
Ascent speed slow or erratic.	1. Weak battery (DC only).	1. Charge battery (see MAINTENANCE section).
	2. Loose connections in electrical circuitry.	1. Perform visual inspection and ensure all connections are secure.
	3. Momentary short in wiring.	1. Refer to electrical schematic.
	4. Bent structural members.	1. Replace damaged members as necessary (see visual structural inspection in MAINTENANCE section).

## TROUBLESHOOTING (CONTINUED)

PROBLEM	POSSIBLE CAUSES	REPAIR PROCEDURE
Ascent speed slow or erratic (continued)	5. Restriction in hydraulic hose.	1. Replace defective hydraulic line.
	6. Defective or jammed seals in hydraulic lift cylinder.	1. Replace hydraulic cylinder.
	7. Gear or gear cavity worn or damaged.	1. Replace pump. (See REPLACEMENT section.)
	8. Worn brushes in motor.	1. Replace brushes.
	9. Defective valves.	1. Check V1 on cylinder manifold.
	10. Loose intake hose or oil filter.	1. Tighten.
	11. Defective down valve in manifold or in cylinder.	1. Replace.
	12. Defective emergency down valve.	1. Replace.
Descent speed slow.	1. Flow control out of adjustment.	1. Adjust (see ADJUSTMENT section).
	2. Friction in structural members.	1. Lubricate and check for damaged members and cracked welds. (See MAINTENANCE.) 2. Replace damaged structural members. This is to be done by factory authorized personnel only.
	3. Obstruction in hydraulic hose.	1. Replace defective hose.
	4. Defective down valve.	1. Replace valve.
Unit will not descend.	1. Down signal not applied to down solenoid.	1. Check fuse. 2. Check battery charge. 3. Check faulty wiring. Refer to wiring diagram.
	2. Faulty down solenoid.	1. Replace worn solenoid.
Unit creeps down.	1. Damaged seal in lift cylinder.	1. Replace hydraulic cylinder (see MAINTENANCE section).
	2. Defective down valve.	1. Replace valve.
	3. Defective emergency down valve.	1. Replace valve.

# ELECTRICAL WIRING DIAGRAM

16DC 12 VOLT

24DC 12 VOLT

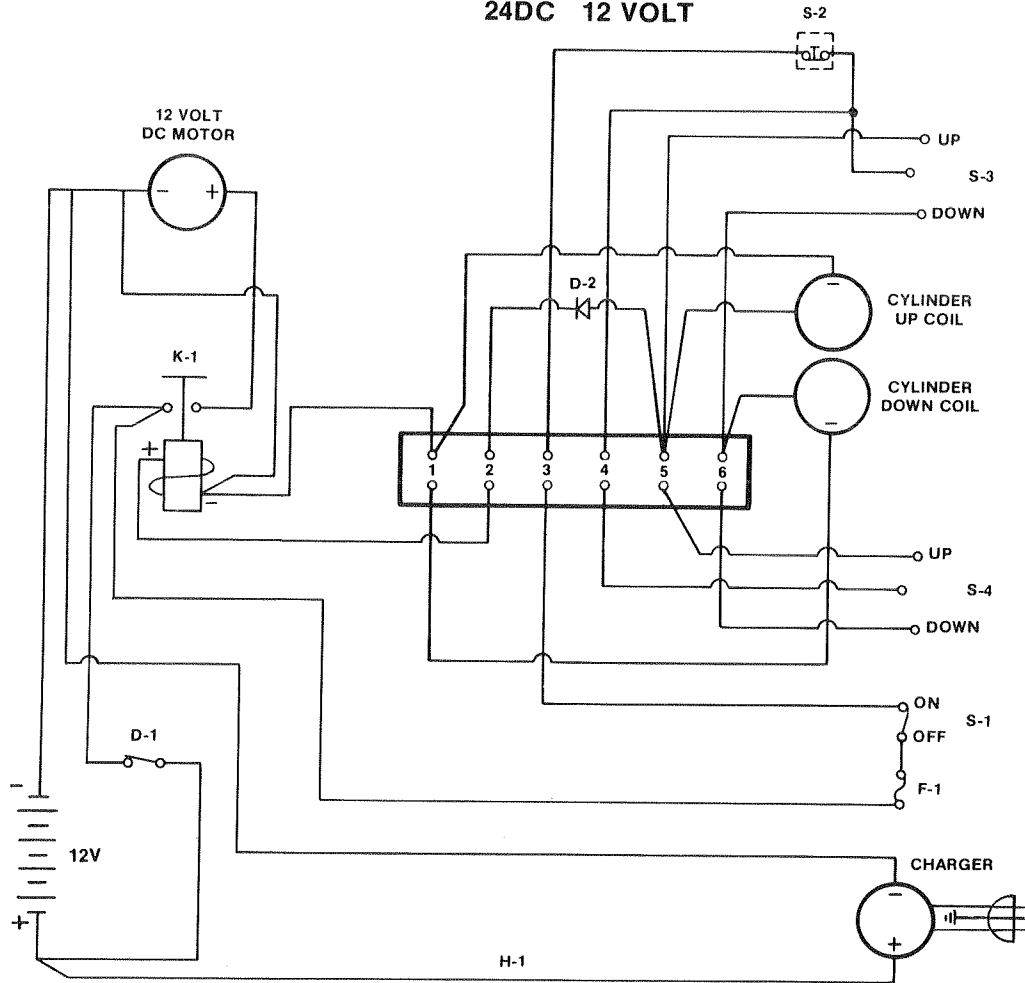

\* NOTE: Switch wiring as seen from rear of switch.

Figure 9.

## Symbol Identification for Figure 9.

Symbol	Description	Part No.
F-1	Fuse	6190
D-1	Battery Disconnect	6468
D-2	Diode	6536
H-1	Wiring Harness	6494
K-1	Start Solenoid	6411
S-1	Key Switch	5936
S-2	Emergency Stop:	
	Body	6665
	Retainer	6666
	Contact	6667
S-3	Platform Control	5230
S-4	Lower Control Switch	5230
	Charger	6382
	Battery	6390
	12-Volt DC Motor	6387
	Coils	6415

# ELECTRICAL WIRING DIAGRAM

16AC  
24AC

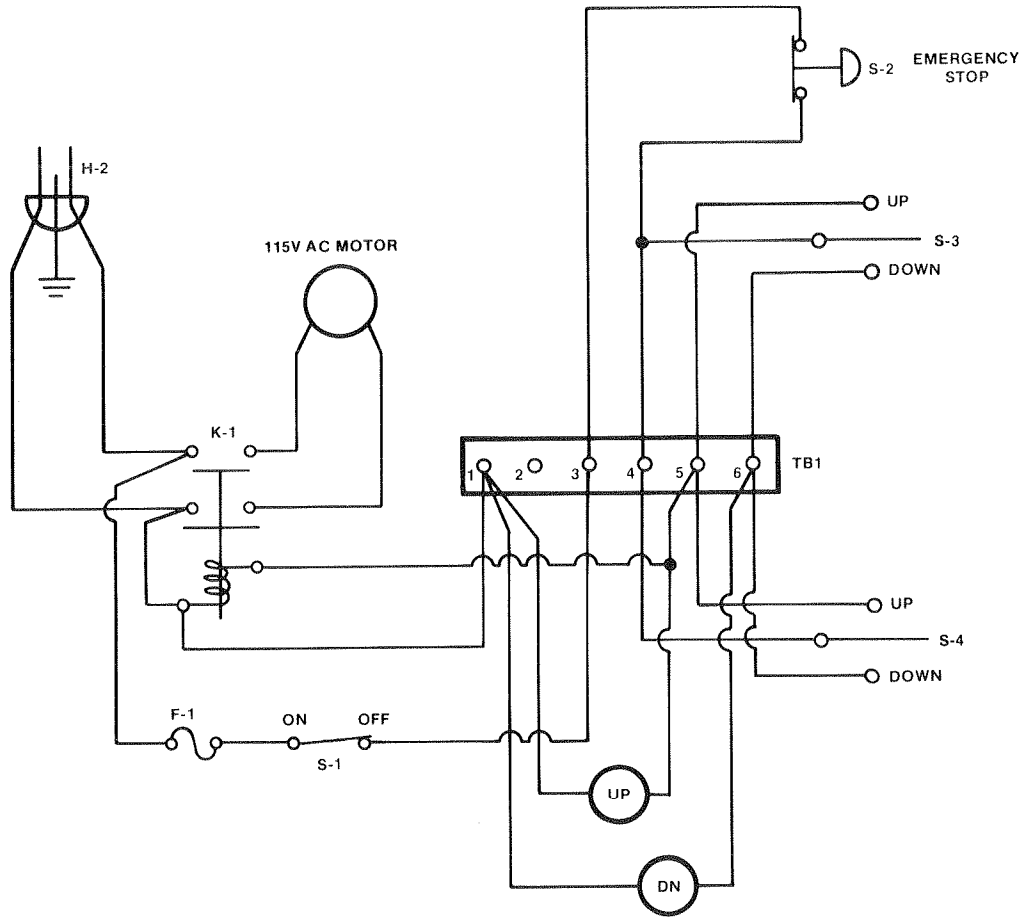

\* NOTE: Switch wiring as seen from rear of switch.

**Figure 10.**

### Symbol Identification for Figure 10.

Symbol	Description	Part No.
F-1	Fuse	6190
H-1	Wire Harness	6508
H-2	AC Cord	6454
K-1	Relay	5397
S-1	Key Switch	5936
S-2	Emergency Stop:	
	Body	6665
	Retainer	6666
	Contactor	6667
S-3	Platform Control	5230
S-4	Lower Control Switch	5230
TB-1	Terminal Board	6470
	Coils	6528
	AC Motor	6401



## HYDRAULIC SCHEMATIC MANIFOLD BLOCK (ALL MODELS)

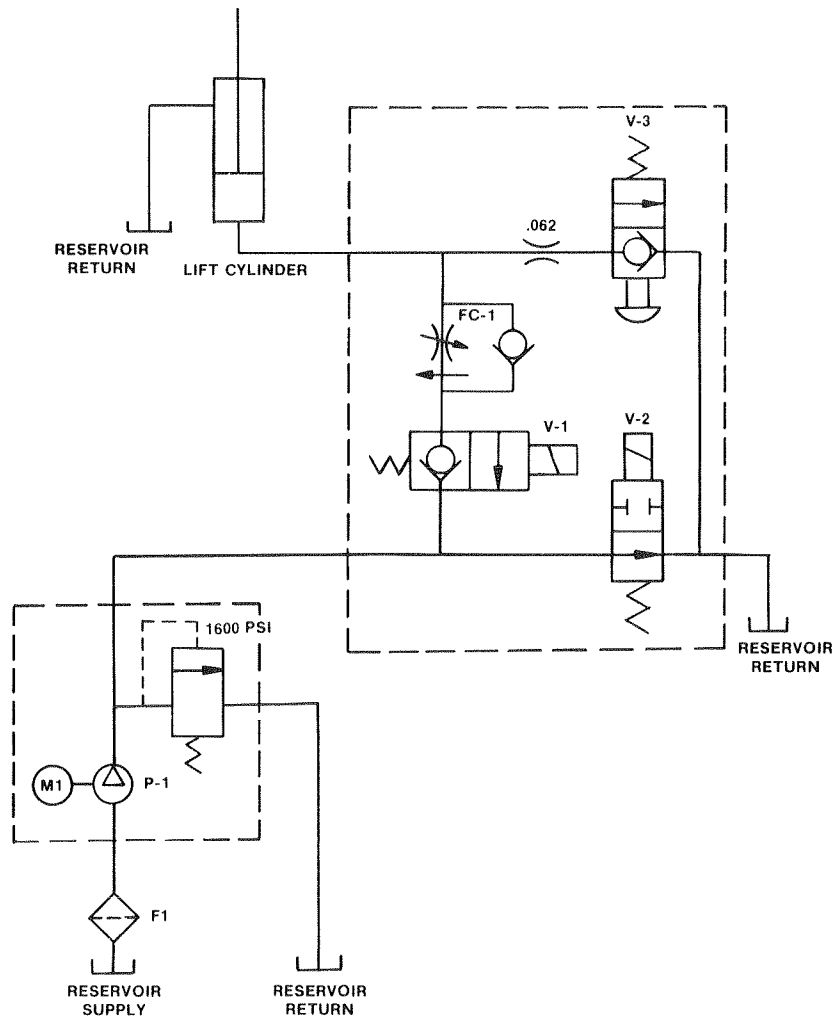

Figure 11.

### Symbol Identification for Figure 11.

Symbol	Description	Part Number	
		DC	AC
F-1	Tank Filter	6377	6377
FC-1	Flow Control "O" Ring Kit	5963	5963
		5475	5475
M-1	Motor	6387	6401
P-1	Pump	6383	6402
V-1	2-Way N.C. Valve "O" Ring Kit Valve Only Coil Only	6453	6506
		5475	5475
		5964X	5964X
		6415	6528
V-2	2-Way N.O. Valve "O" Ring Kit Valve Only Coil Only	6452	6505
		5475	5475
		5962X	5962X
		6415	6528
V-3	Manual Pull - Emergency Down "O" Ring Kit	5435	5435
		5475	5475

## HYDRAULIC MANIFOLD

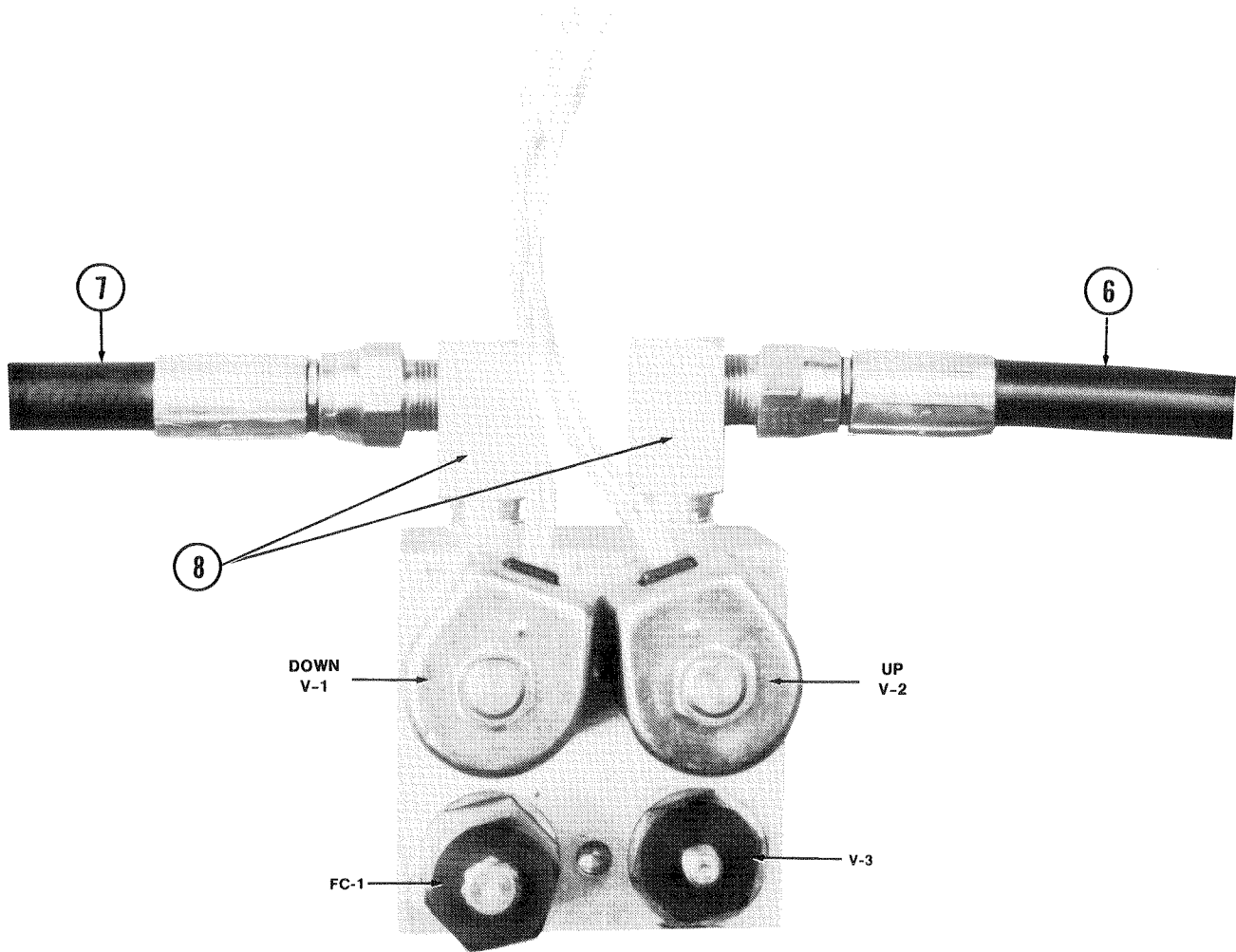

Figure 12.

### Symbol Identification for Figure 12.

Symbol	Description	Part Number	
		AC	DC
V-1	2-Way Valve (N.C.)	6506	6453
V-2	2-Way Valve (N.O.)	6505	6452
V-3	Manual Pull Valve	5435	5435
FC-1	Flow Control Valve	5963	5963
	Coils Only	6528	6415
6	Hose - Tank to Manifold	6430	6430
7	Hose - Pump to Manifold	6429	6429
8	Fitting Elbow	6360	6360

# 5. PARTS CATALOG

## IMPORTANT REPLACEMENT PART NOTES

### 1. CAPSCREWS

**ANY BOLT REPLACEMENT SHOULD BE OF THE SAME GRADE OR GREATER THAN ORIGINAL BOLT. ANY QUESTIONS, CALL FACTORY FOR VERIFICATION.**

Grade markings for cap screws grades 2, 5, and 8 are based on SAE J429. Markings may be raised or depressed (manufacturer's option).

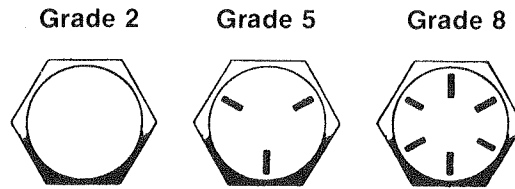

### 2. BATTERY

Replacement battery **MUST WEIGH AT LEAST 60 POUNDS**, to maintain the stability factor of the machine.

### 3. CASTERS

Casters must be replaced with manufacturer's replacement casters to maintain stability factor of the machine.

### 4. DECALS AND LABELS

All decals and labels are furnished at no charge. Refer to the following part numbers when requesting decals. See page 24 for proper location of specific safety decals.

Part No.	Description	
2979	16AC	Decal Kit
2980	16DC	Decal Kit
2981	24AC	Decal Kit
2982	24DC	Decal Kit

## IMPORTANT

**When servicing machine check to see if decals shown in diagram below are in place and legible. If not, they must be added or replaced.**

**NOTE:** Make sure capacity decals match capacity of machine.

# IMPORTANT

When servicing machine check to see if decals shown in diagram below are in place and legible. If not, they must be added or replaced.

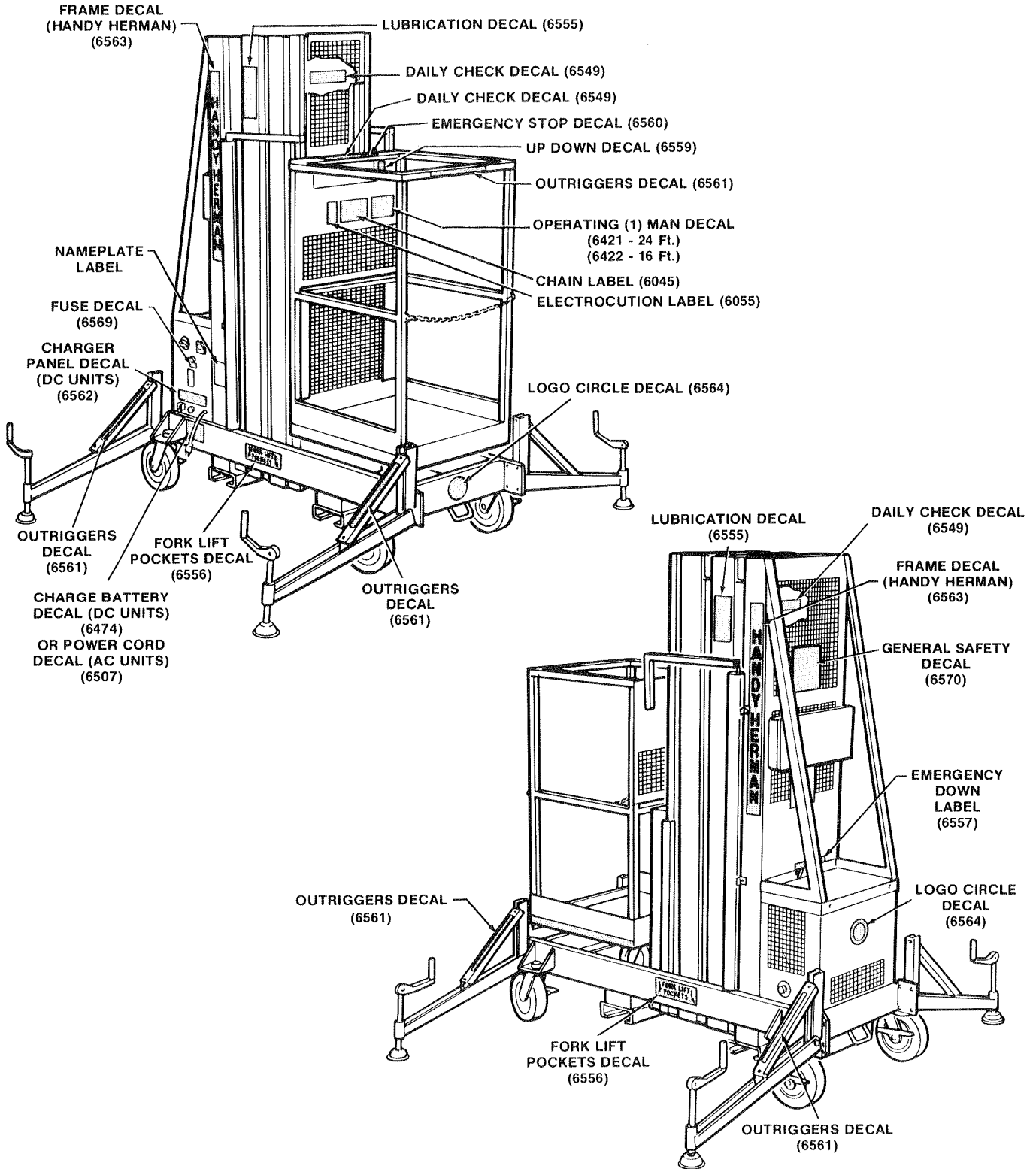

**NOTE:** Make sure capacity decals match capacity of machine on nameplate.

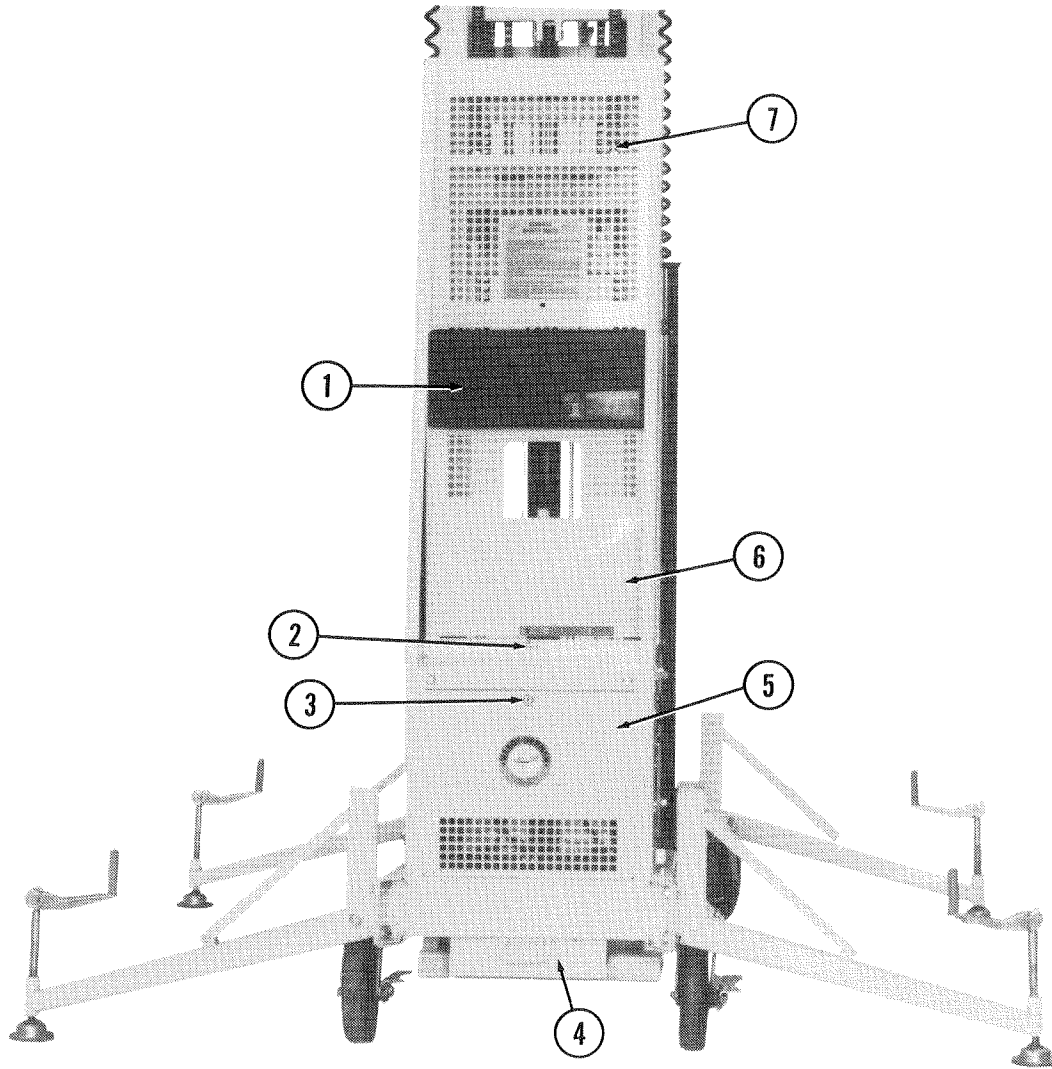

Figure 13.

Item	Description	16AC Part No.	24AC Part No.	16DC Part No.	24DC Part No.
1	Box - Service Manual	6311	6311	6311	6311
2	Emergency Down Assy.	2817	2817	2817	2817
3	Lock	6413	6413	6413	6413
4	Battery Tray			2754	2754
5	Panel - Rear Entry	2755	2755	2755	2755
6	Reservoir Weldment	2723	2723	2723	2723
7	Rear Mast Guard	2964	2964	2964	2964

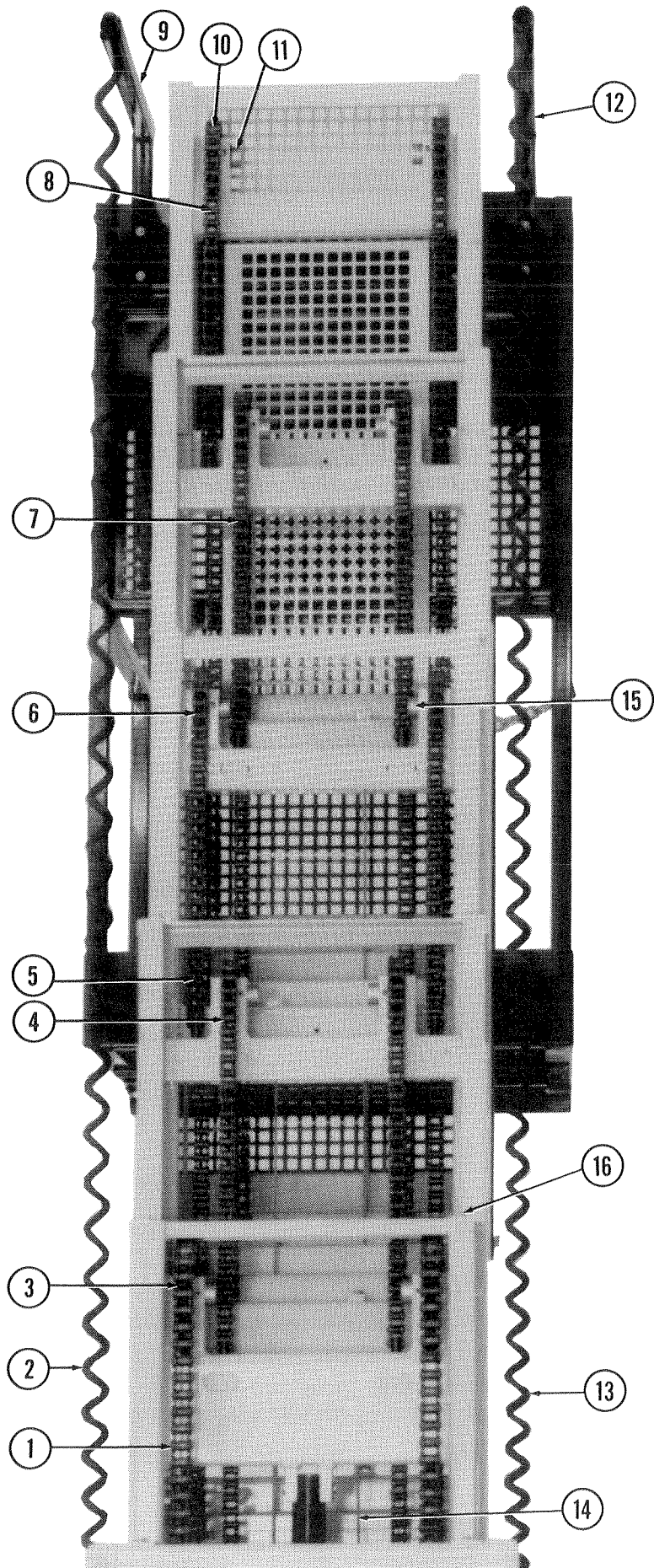

Figure 14.

<b>Item</b>	<b>Description</b>	<b>16AC Part No.</b>	<b>24AC Part No.</b>	<b>16DC Part No.</b>	<b>24DC Part No.</b>
1	#60 Chain Assy.	6538	6538	6538	6538
	#60 Chain Connecting Link	6542	6542	6542	6542
2	Retractable Control Cord	6512	6512	6398	6398
3	#60 Sprocket Assy.	2942	2942	2942	2942
4	#50 Chain Assy.	6539	6539	6539	6539
	#50 Chain Connecting Link	6541	6541	6541	6541
5	#50 Sprocket Assy.	2943	2943	2943	2943
6	#50 Chain Assy.	6539	6539	6539	6539
	#50 Chain Connecting Link	6541	6541	6541	6541
7	#50 Chain Assy.		6539		6539
	#50 Chain Connecting Link		6541		6541
8	#50 Chain Assy.		6539		6539
	#50 Chain Connecting Link		6541		6541
9	Wire Support R.H.	2812	2806	2812	2806
10	#50 Sprocket Assy.	2943	2943	2943	2943
11	Sprocket Pivot Pin (All)	2959	2959	2959	2959
12	Wire Support L.H.	2813	2807	2813	2807
13	110V Retractable Cord	6389	6389	6389	6389
14	Retractor Cable	6403	6403	6403	6403
	Retractor Cable, Cyl. Sect.	6545	6545	6545	6545
	Pulley - Retractor Cable	2747	2747	2747	2747
15	Expansion Pin	6419	6419	6419	6419
16	Slide Retainer	2769	2769	2769	2769



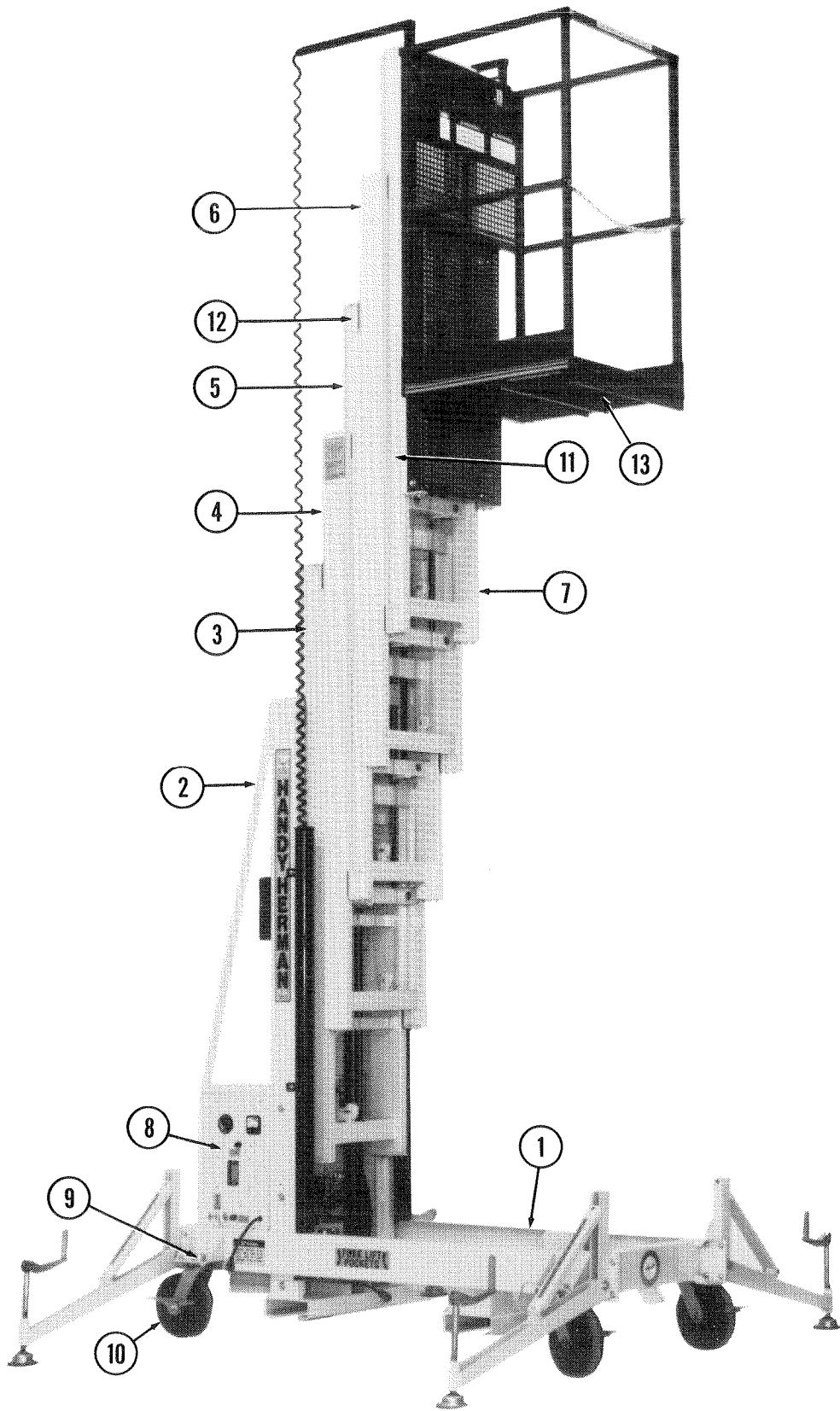

Figure 15.

<b>Item</b>	<b>Description</b>	<b>16AC Part No.</b>	<b>24AC Part No.</b>	<b>16DC Part No.</b>	<b>24DC Part No.</b>
1	Base Weldment	2673	2673	2673	2673
2	Main Mast Weldment	2939	2939	2939	2939
3	Mast Section - Cylinder	2911	2911	2911	2911
4	Outer Mast Section	2922	2922	2922	2922
5	Inner Mast Section	2932	2931	2932	2931
6	Outer Mast Section		2922		2922
7	Inner Mast Section		2932		2932
8	Panel Assy. (Charger or 110)	Detail	Detail	Detail	Detail
9	Leveling Circle	6412	6412	6412	6412
	Base - Level	2867	2867	2867	2867
	Cover - Level	2866	2866	2866	2866
10	Caster, Swivel, w/Brake	6388	6388	6388	6388
11	Platform Mast Section	2935	2935	2935	2935
12	Guide Pad	6409	6409	6409	6409
13	Platform Weldment	Detail	Detail	Detail	Detail

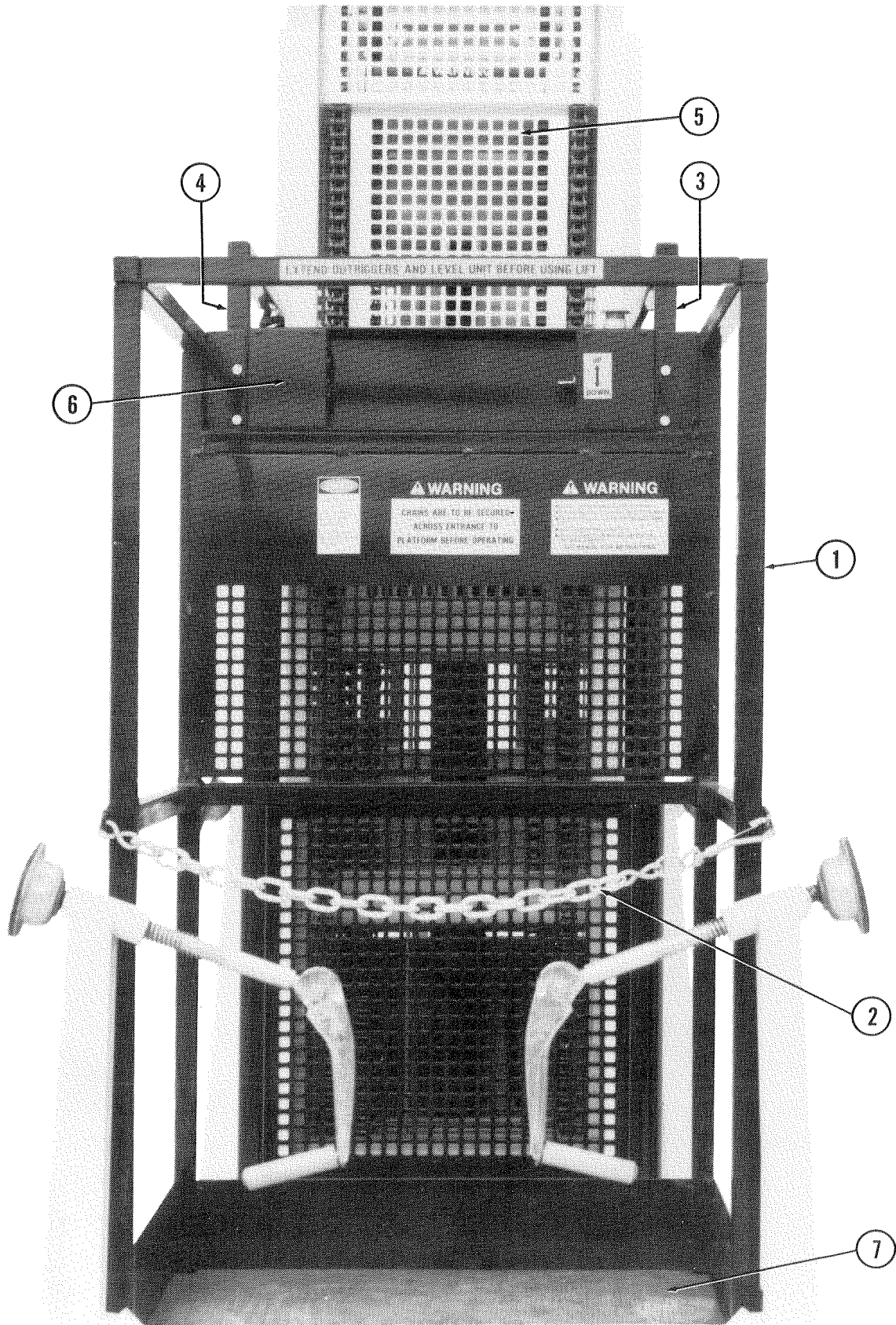

Figure 16.

<b>Item</b>	<b>Description</b>	<b>16AC Part No.</b>	<b>24AC Part No.</b>	<b>16DC Part No.</b>	<b>24DC Part No.</b>	<b>Narrow Part No.</b>
1	Platform Weldment	2643	2642	2643	2642	2800
2	Safety Chain Assy.	2756	2756	2756	2756	2863
3	Wire Support Weld R.H.	2812	2806	2812	2806	2806
4	Wire Support Weld L.H.	2813	2807	2813	2807	2807
5	Guard Front	2757	2757	2757	2757	—
6	Upper Control Box	2803	2803	2803	2803	2803
	Switch Bracket	2804	2804	2804	2804	2804
	Outlet Bracket	2805	2805	2805	2805	2805
	Duplex Receptacle	5381	5381	5381	5381	5381
	Switch Emergency Stop:					
	Emergency Stop Body	6665	6665	6665	6665	6665
	Emergency Stop Retainer	6666	6666	6666	6666	6666
	Emergency Stop Contactor	6667	6667	6667	6667	6667
	Switch Toggle	5230	5230	5230	5230	5230
7	Floor Board	6405	6386	6405	6386	6501

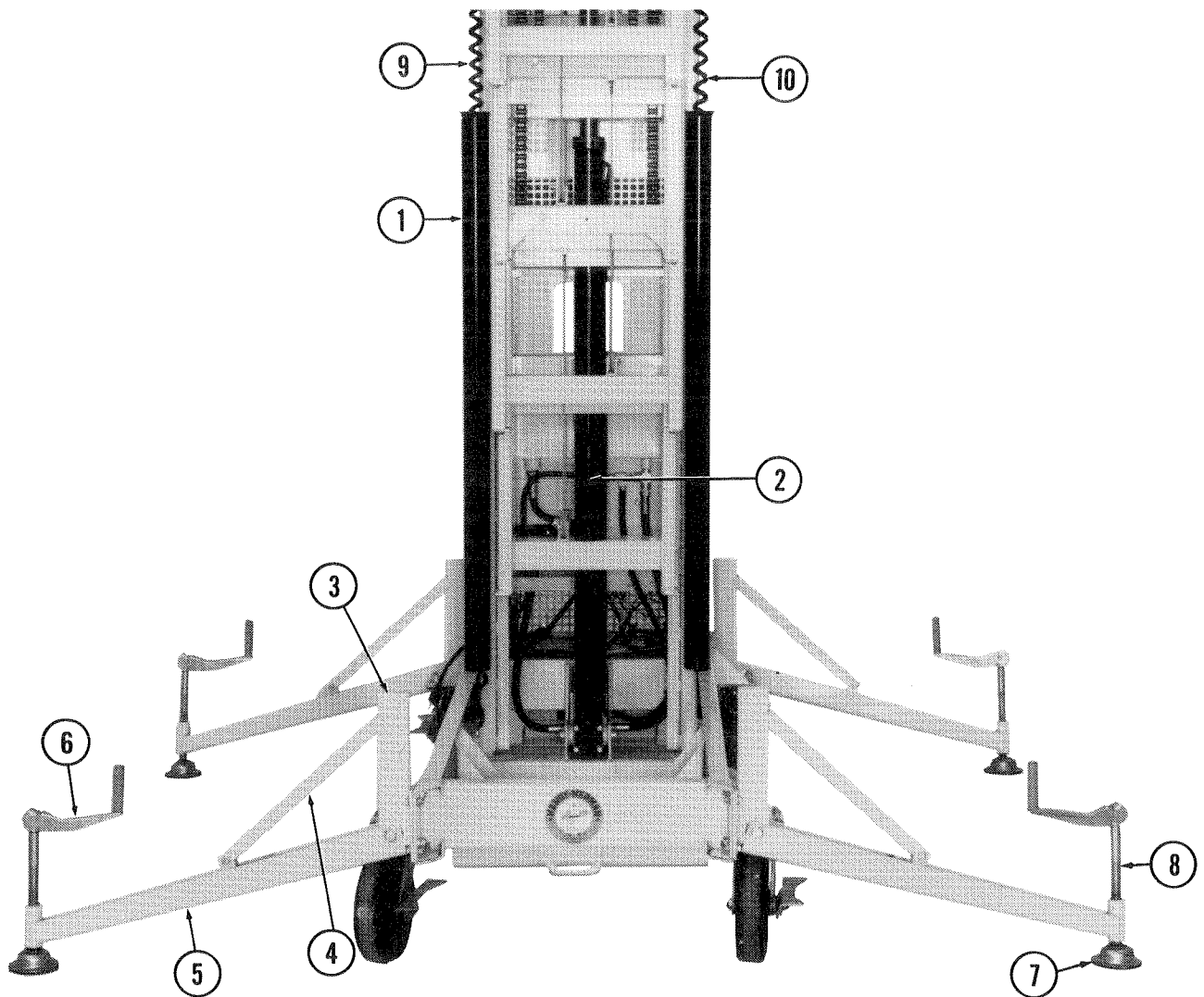
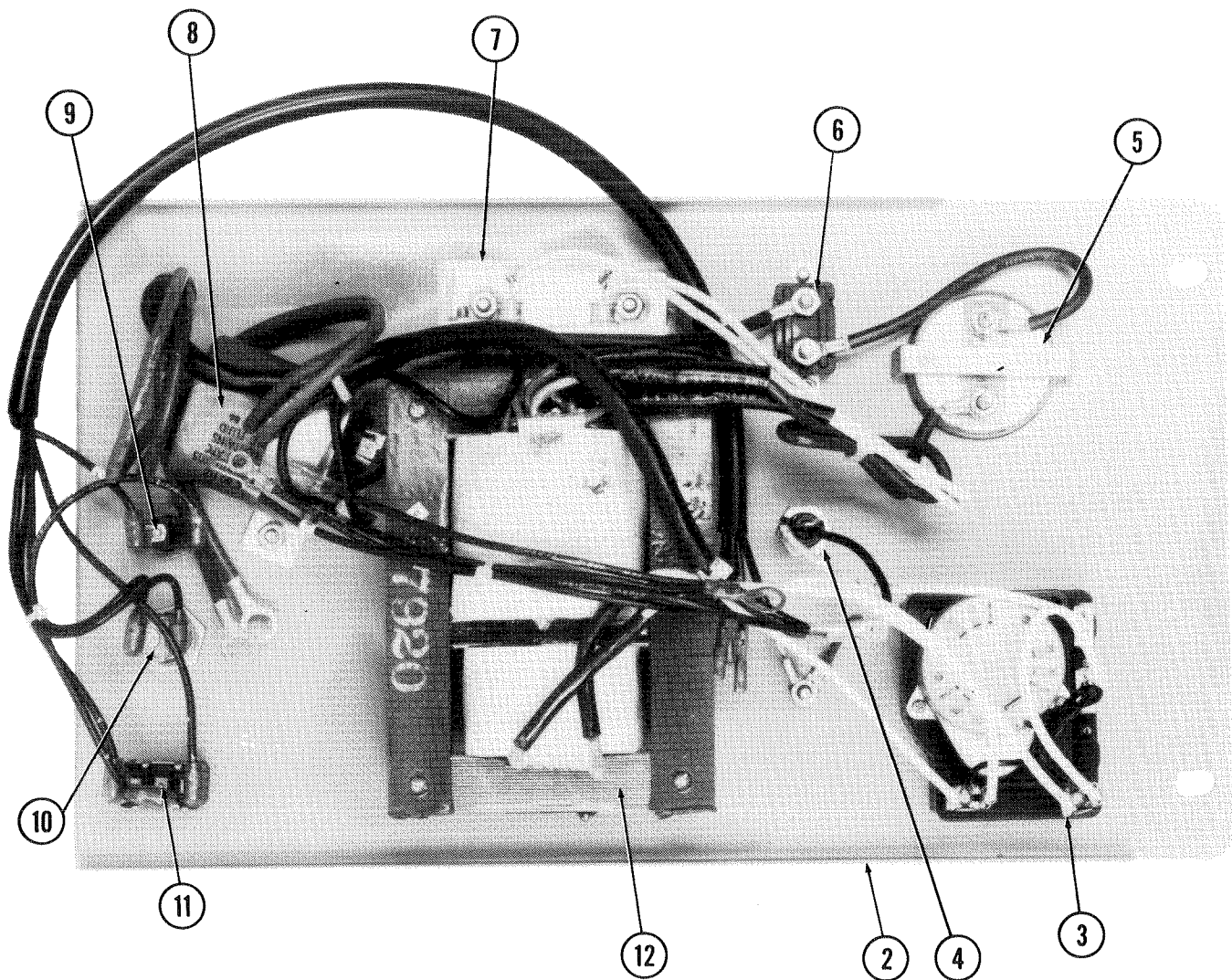

Figure 17.

Item	Description	16AC Part No.	24AC Part No.	16DC Part No.	24DC Part No.
1	Coil Cord Tube Weldment	2884	2884	2884	2884
2	Cylinder Assy.	Detail	Detail	Detail	Detail
3	Outrigger Mtg. Brkt. Weldment	2653	2653	2653	2653
4	Outrigger Brace	2657	2657	2657	2657
5	Outrigger Arm Weldment	2649	2649	2649	2649
6	Jack Handle	5438	5438	5438	5438
7	Outrigger Pad	2749	2749	2749	2749
8	Adjustment Screw	2658	2658	2658	2658
9	110V Retractable Cord	6389	6389	6389	6389
10	Retractable Control Cord	6512	6512	6398	6398
	Nut	6463	6463	6463	6463
	Washer	6407	6407	6407	6407



**Figure 18. DC Control Panel Assembly**

Item	Description	Part No.
1	DC Control Panel Assembly (As Shown)	2874
2	Charger Panel	2721
3	Timer	6518
	Timer Knob	5556
	Timer Dial	6519
4	Fuse Holder*	6170
5	Ammeter	6520
6	Circuit Breaker	6522
7	Rectifier Assembly	6521
8	Condenser	6517
9	Fuse Holder	5265
	Fuse (10 Amp)	6190
10	Key Switch	5936
11	Toggle Switch	5230
12	Transformer	6516
*	Fuse for 6527 (15 Amp)	6526

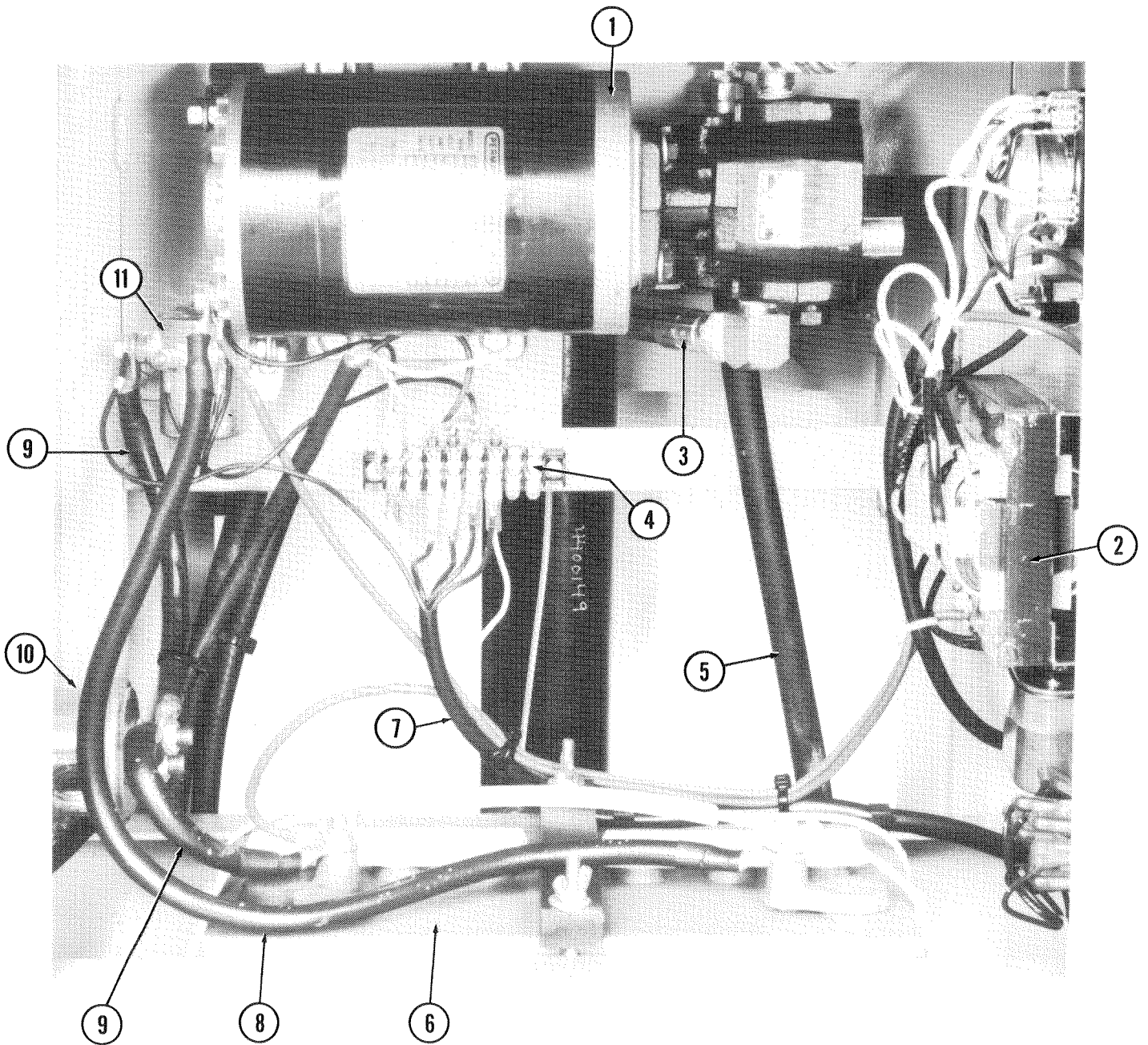
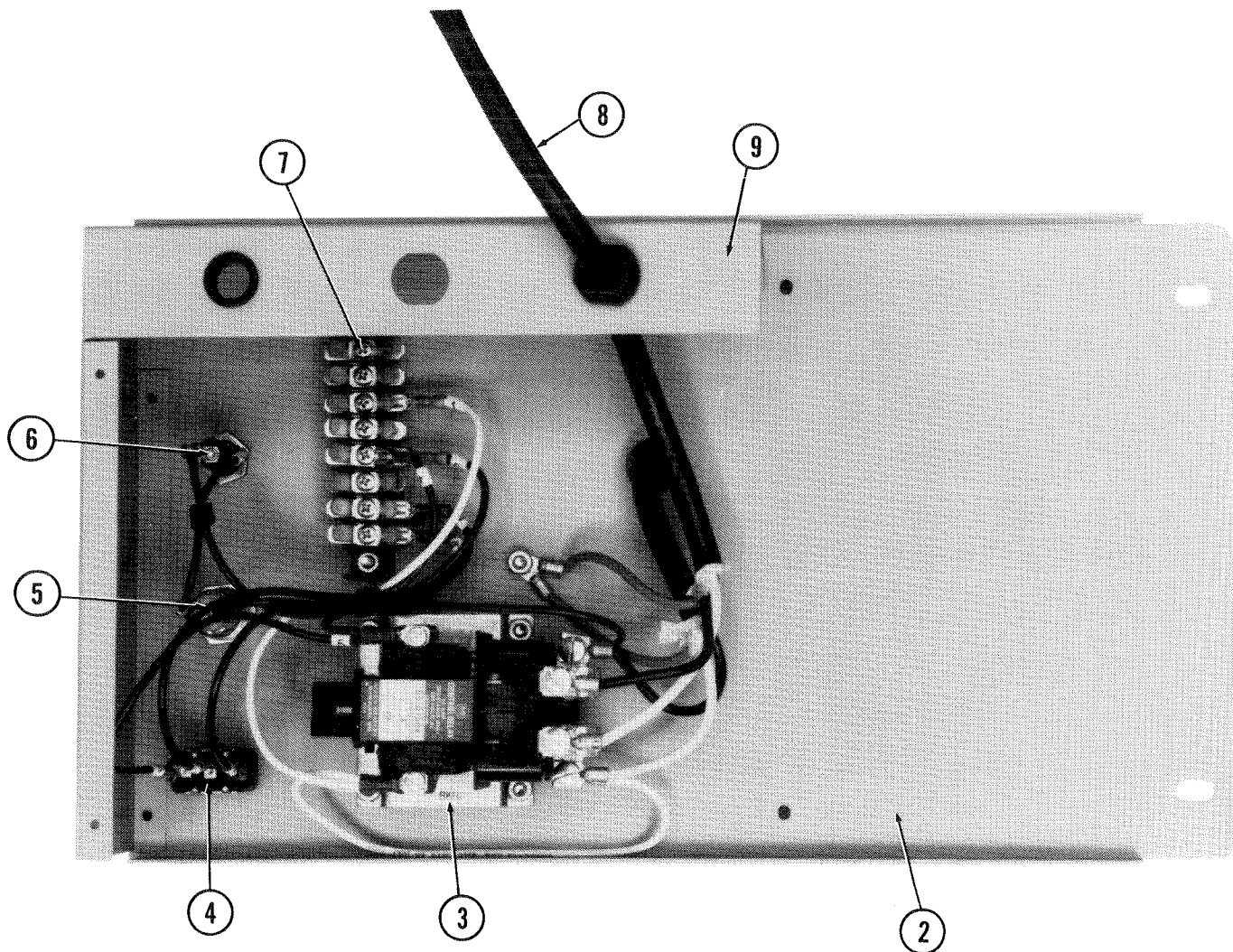

Figure 19.



Item	Description	Part Number	
		AC Unit	DC Unit
1	Pump and Motor Assy.	Fig. 22	Fig. 21
2	Charger/AC Panel Assy.	Fig. 20	Fig. 18
3	Hose - Tank to Pump	6437	6437
4	Terminal Board		6470
5	Hose - Pump to Manifold	6429	6429
6	Battery - 12V		6390
7	Main Harness	6508	6494
8	Battery Cable		6427
9	Battery Cable		6428
10	Switch Battery Disconnect		6468
	Side Panel	2728	2728
	Face Plate - Switch		6469
11	Contactor - 12V		6411
12	Battery Cable - Contactor to Motor (Not Shown)		6208



**Figure 20. AC Control Panel Assembly**

Item	Description	Part No.
1	AC Control Panel Assembly (As Shown)	2873
2	Side Panel 110	2729
3	Relay	5397
4	Toggle Switch	5230
5	Key Switch	5936
6	Fuse Holder	5265
	Fuse	6190
7	Terminal Board	6470
8	Power Cord - AC	6454
9	Safety Bracket - AC	2842
	Cover (Not Shown)	2843

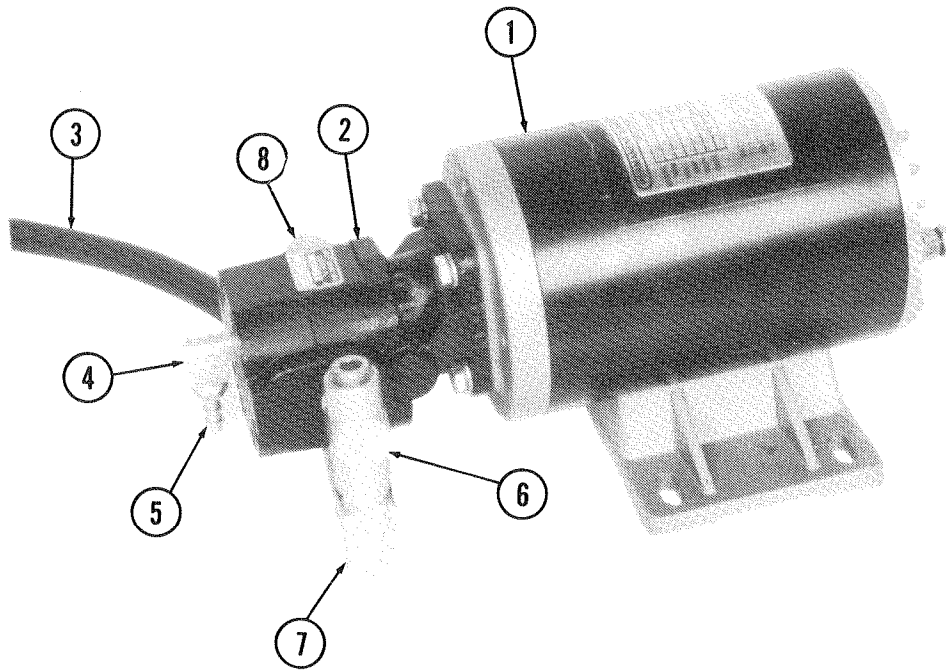

Figure 21.

Item	Description	Part No.
1	Motor DC	6387
2	Pump DC	6383
3	Hose - Pump to Manifold	6429
4	Street Elbow L.P.	5122
5	Bayonet Fitting	5052
6	Fitting, Tee	6446
7	Fitting, Elbow (SPLL.)	6360
8	Fitting Street Elbow H.P.	5472

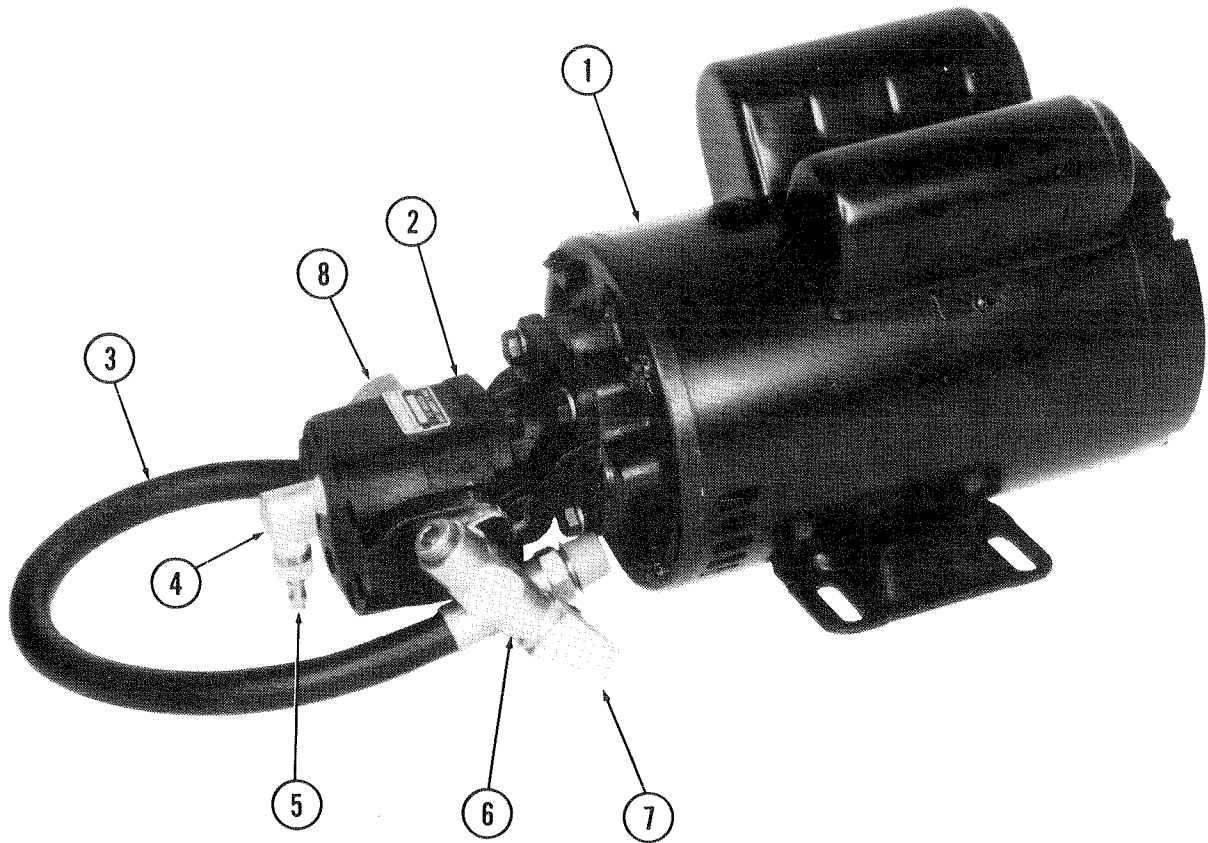

Figure 22.

Item	Description	Part No.
1	Motor AC	6401
2	Pump AC	6402
3	Hose - Pump to Manifold	6429
4	Street Elbow L.P.	5122
5	Bayonet Fitting	5052
6	Fitting, Tee	6446
7	Fitting, Elbow (SPLL.)	6360
8	Fitting, Street Elbow H.P.	5472

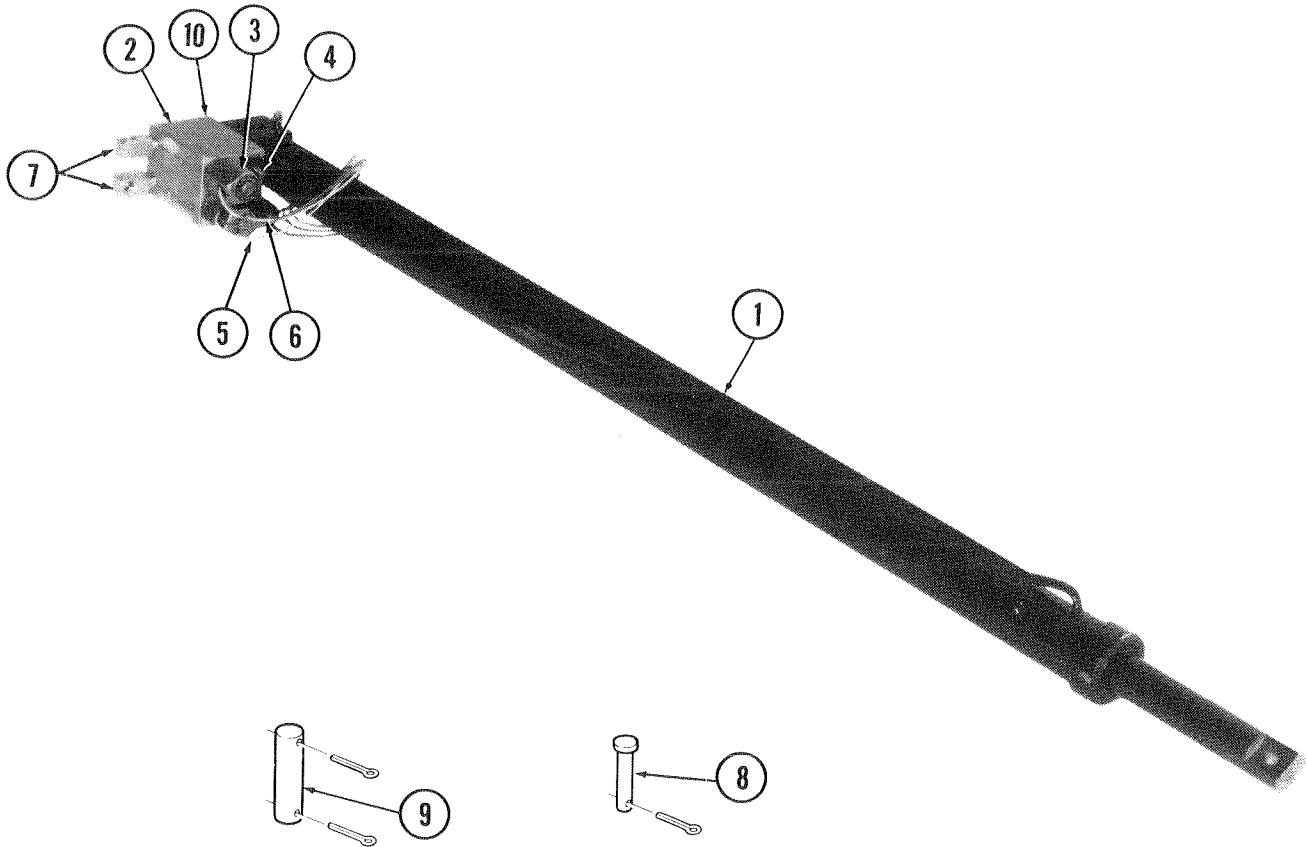
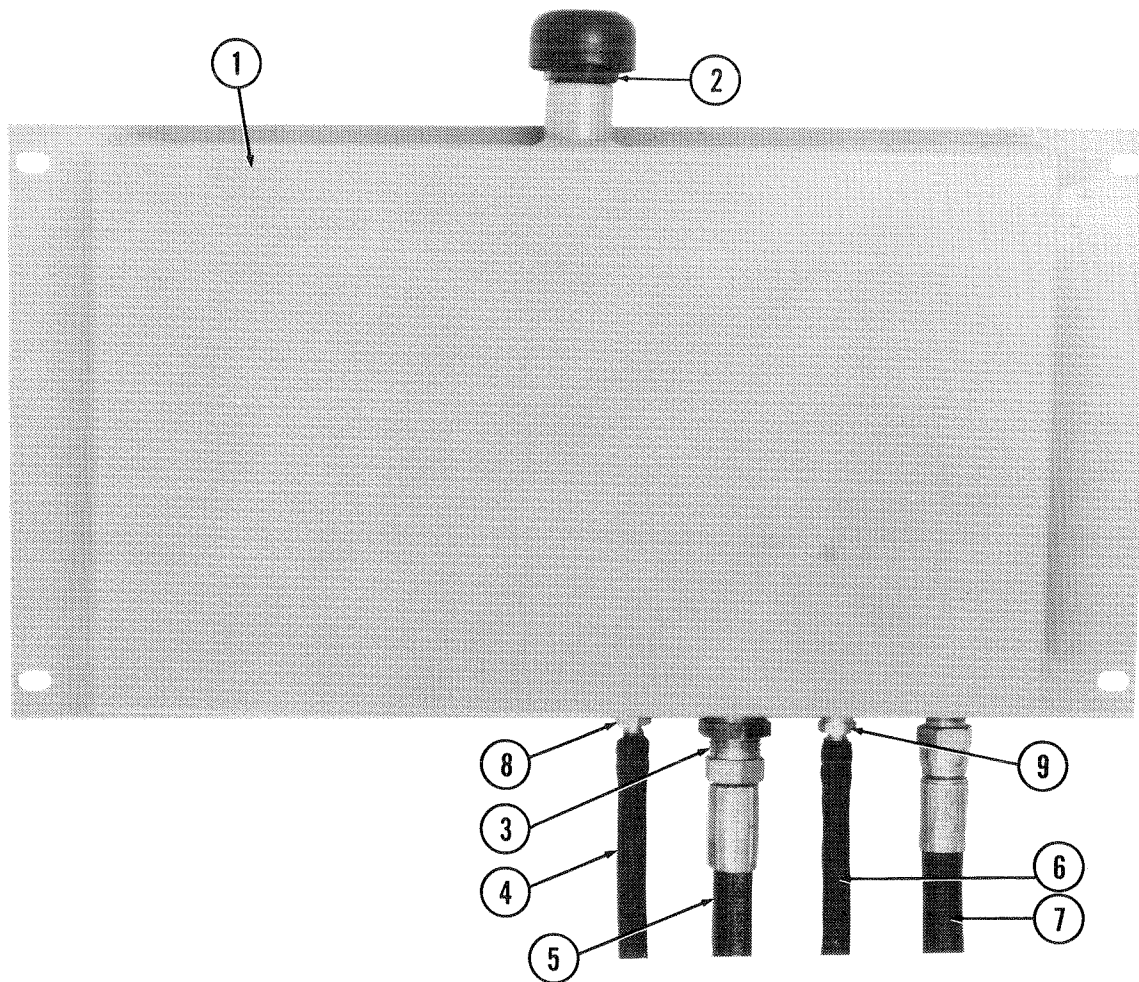

Figure 23.

Item	Description	Part Number	
		AC Unit	DC Unit
1	Hydraulic Cylinder	6373	6373
	Cyl. Repair Kit (Columbus Cyl.)	6597	6597
2	Manifold	2730	2730
3	Valve 2-Way (N.O.)	6505	6452
4	Valve - Manual Pull	5435	5435
5	Valve 2-Way (N.C.)	6506	6453
6	Valve - Flow Control	5963	5963
7	Fitting Elbow	6360	6360
	Coils	6528	6415
8	Cyl. Pin, Upper	6406	6406
	Cotter Pin	5920	5920
9	Cyl. Pin, Lower	2766	2766
	Cotter Pin	5290	5290
10	O-Ring - Manifold to Cyl.	6426	6426



**Figure 24.**

Item	Description	Part No.
1	Reservoir Weldment	2723
2	Breather Cap	6284
—	Gage	2882
3	Filter	6377
4	Hose - Return Line 1/4 I.D.	4172
5	Hose - Tank to Pump	6437
6	Hose - Return Line 5/16 I.D.	4173
7	Hose - Tank to Manifold	6430
8	Fitting - Bayonet 1/4"	5052
9	Fitting - Bayonet 5/16"	6459